

# Log Periodic Dipole Array for 2 Meters

*Wideband performance in a small package.*

by Dave Koslow N2KLLK

I wanted an antenna for backpacking that would be very portable, very small, have high gain, a good f/b ratio, and cover the whole 2m band. Not a small wish list!

Consulting my trusty *ARRL Antenna Book*, I experimented with quads (too bulky and fragile), verticals/ground planes (low gain and not directional), and yagis (too big physically, and small bandwidth). Then I found what seemed to be my dream antenna—the Log Periodic Dipole Array. Never seen one? Just look at the roofs in your neighborhood—many TV antennas are LPDAs!

## The LPDA

In these antennas the elements are all driven, and each half is fed 180 degrees out of phase with the other. The feedpoint is at the front of the antenna. All the characteristics, such as SWR, gain, f/b ratio, and pattern, are fairly constant over the entire operating bandwidth. This means you don't have to optimize the antenna for a small segment of the 2 meter band. You can work any mode anywhere in the 4 MHz range and expect consistent performance. At VHF and above, the feeders can double as the boom. This allows for simple, solid construction. While all elements are driven in this system, not all are active at any particular frequency. As the operating frequency changes, so does the area of the antenna that is resonant. The remaining elements act like reflectors and directors. (*The ARRL Antenna Book*, 15th Edition, pp. 10-1 to 10-7.)

With the help of a spreadsheet, scientific calculator, and lots of tea, I worked through the equations to optimize a design. Believe me, this is one antenna project where math had better be your friend!

I arrived at a 5-element design

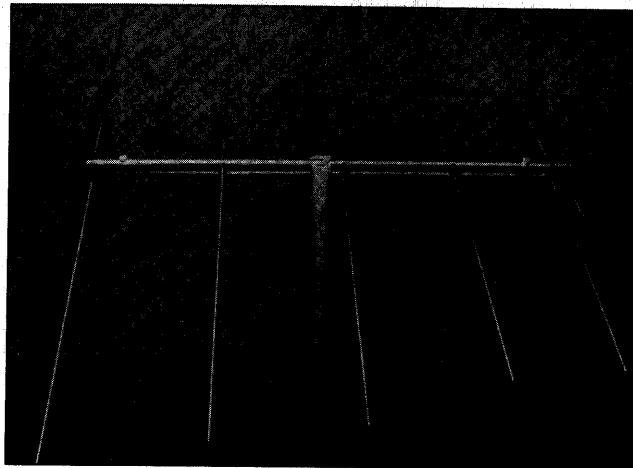

Photo A. Inside full view, horizontal polarization.

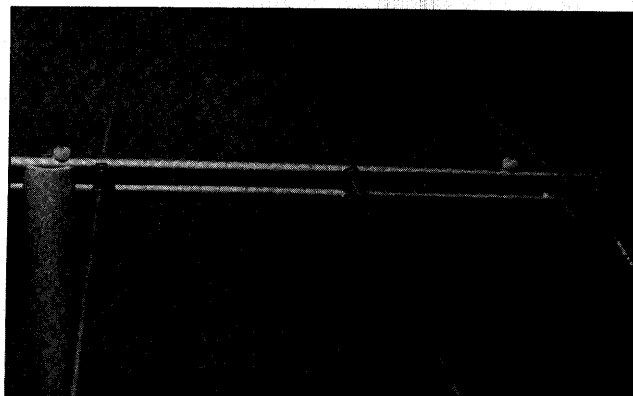

Photo B. Detail of the boom and element, horizontal polarization.

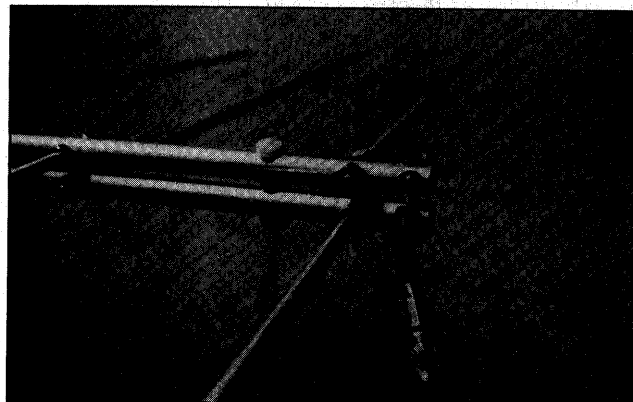

Photo C. Detail of the boom, element assembly and feedpoint attachment.

that gave 9 dB gain, about 15 dB f/b ratio, and all on a 2-foot boom! My finished antenna collapses to a bundle about 25" x 1.5" and weighs a little over a pound. Not too shabby, huh? Because of its small size, this is also an excellent "stealth" antenna for condos that don't like hams. It looks just like a tiny TV antenna. Its portability and high gain also make it perfect for emergency communications.

I built a prototype from plumbing pipe and old bits of TV antenna to prove out the design. Later, I made an interesting discovery—the prototype's performance was a close match for the final version that I machined!

My final antenna basically consists of two parallel feeders of 1/2" aluminum tube and five sets of elements of 1/4" aluminum rod. You should be able to find this in any good hardware store. The feeders are held together with a fixed gap by nylon hardware and washers. (Sets of nylon hardware, sufficient for two antennas, are available for \$4 from: Dave Koslow N2KLLK, 3315 Hamilton Rd., Fairlawn NJ 07410.)

Clearly, here is a case where measurement, not material, is important. I have included data on various element and feeder diameters so you can build one out of what you have at hand.

## Construction

You will need some basic metal working tools and skills. Later in this article I have included some alternative suggestions for construction using simpler techniques.

Cut the two boom sections to 27". You will need a drilling jig and drill press to make accurate holes. I made up a block of wood, slightly longer than the boom section, with a "V" notch about 3/8" deep down the long axis. Lay the boom section in the groove and

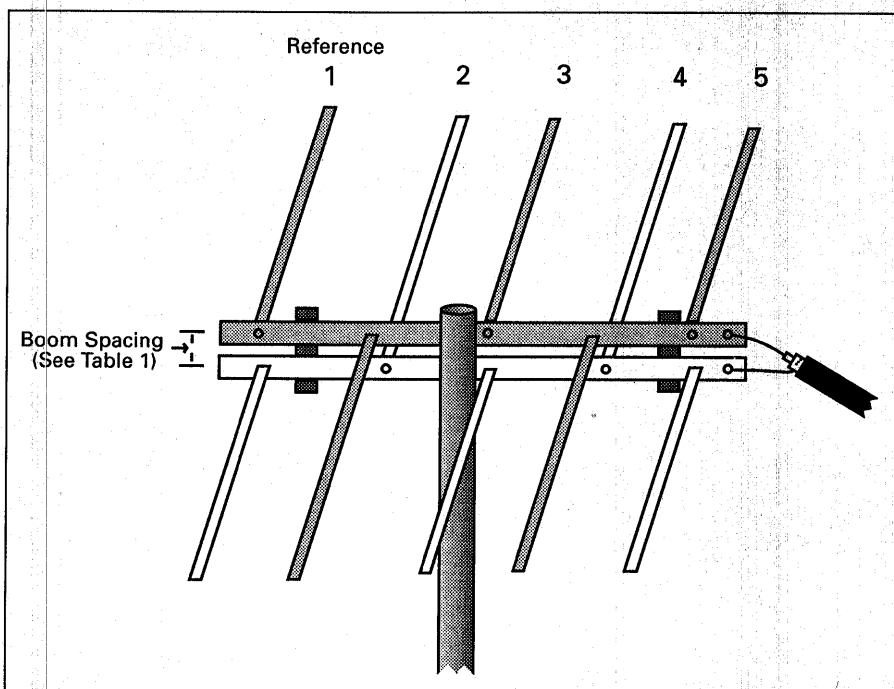

Figure 1. Construction details of the LPDA antenna. Note that the feedpoint is located 1/2" in front of the shortest element pair.

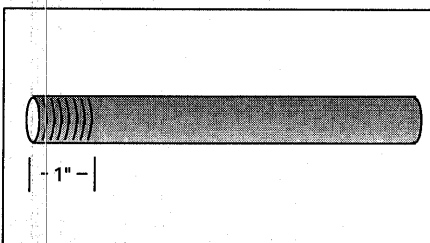

Figure 2. Cut each element 1-1/4" longer than shown in Table 1. Then cut a 1" length of screw threads on one end of each element using a 1/4-20 tap and die set.

scribe a line down its length with a pencil, using the block surface as a guide. This will be your drilling line.

Now rotate the tube so that the line is perpendicular to the block. Drill a small hole at each end of the boom section and secure the boom to the block with a small screw. Now lay out the hole spacing, starting with the first hole about 1-1/4" from an end. The measurements for hole spacing and element length are given in metric terms for greater accuracy. Mark each point with a center punch or hammer and nail to prevent drill skip. Drill and tap each hole for a 1/4-20 thread. These are for the elements to screw into. Drill a small hole, about 1/2" forward of the smallest element. This will be the feedpoint. Remove the boom from the jig, rotate 90 degrees, then secure it again with small holes and screws at the ends. Now drill three 1/4" clearance holes, at about 3", 13" and 23" from the longest element end. These are for securing the two boom halves. Repeat the process for the second sec-

tion. Cut off the excess boom material, about 1/4" behind the longest element, and 1/4" in front of the feedpoint. Assemble the two boom sections together with nylon hardware and sufficient washers to provide the specified gap. The two halves must be insulated from each other, as they are the active parts of the feeder.

Cut each element about 1-1/4" longer than the finished size to allow for threading and tuning. Using a 1/4-20 die, cut about 1" of threads on one end of each rod element (see Figure 2). Put a nut on each element, spinning it down to the bottom of your threaded section, and tighten it in place with a wrench. In a LPDA, the feedpoint is at the front of the antenna, so the smallest element goes here. Each element half is screwed in to the boom, alternating top-left to bottom-right for the

first element, top-right-to-bottom-left for the second, and so on (see the photos and Figure 1). This is to give a 180 degree phase shift to each pair. Attach a nut, finger-tight, to the element segment protruding from the boom. Measure each element length from the boom center and file or grind off the excess. Do the same with the threaded element past the nut. To attach the feedline, solder the conductor and shield to small brass washers and secure to the boom with brass hardware.

#### Alternatives

There are many ways to construct a LPDA. My two antennas were radically different in construction style and both work fine. In my prototype, the elements were 3/8" aluminum rolled tubes from an old TV antenna, held in to a copper tube boom with sheet metal screws. The boom insulators were PVC pipe welded together.

If you can't find aluminum tubing, 1/2" copper tubing works just fine. Because of the difference in diameter (it is really 0.625" o.d.), the antenna requires a different spacing of the boom halves. See Table 1 for the specifications. If you don't have access to metal shop tools, try contacting a local high school industrial arts shop. Surely a little fast talking (and maybe a ham radio demo) can get a few pieces threaded and drilled. You could also try using plain aluminum rod with speed nuts instead of threads. This will make portability a bit tough, though. Another possibility is threaded steel rod for the elements. Use your imagination—the dimensions and spacings are all that is critical.

Mounting is somewhat an individual thing, but there are some guidelines to follow. Because the whole antenna is active, it doesn't like metal masts too close. This is especially true with vertical polarization. You should have a nonconductive mast at least 10" beyond the longest element tip before a metal mast. I use a 3' PVC pipe on a small metal mast for backpacking DX. The antenna rests in a slot at the top and is held in place by a slotted PVC end cap. One end has a slot for vertical polarization; the other end is horizontal. This works pretty well for temporary setups. I haven't worked much on a permanent installation. Whatever you come up with, make sure you don't short the two boom halves together. If performance (or SWR) is poor, check that the elements are in proper order, and alternating left-to-right and top-to-bottom. It is very easy to make a mistake, so check carefully. This has "got" me several times in the hills.

I have had great success with this antenna, on repeaters and SSB, everywhere from mountaintops to my back yard. Try it. I think it will be the best portable antenna you've ever had. **73**

Contact Dave Koslow N2KLK at 3315 Hamilton Rd., Fairlawn NJ 07410.

#### Specifications

Frequency range: 144-148 MHz  
Gain: 9 dB  
F/B ratio: 15 dB  
Half-power beamwidth: 25 degrees  
SWR: <1.5:1  
Boom length: 25"  
Longest element: 41 + " (total)  
Packed size: 25" x 1.5"

Finished Element Halves (2 of each)	Element Spacing
Element 1	Reference
Element 2	16.78 cm (6.61")
Element 3	15.52 cm (6.11")
Element 4	14.36 cm (5.65")
Element 5	13.28 cm (5.23")

Boom Spacing (Center-to-Center)	
0.500" boom & 0.250" element	0.614" spacing
0.500" boom & 0.375" element	0.652" spacing
0.625" boom & 0.250" element	0.767" spacing
0.625" boom & 0.375" element	0.815" spacing

Table 1. Log periodic dipole array specifications.