

THE PASE LOCKED LOOP (As used for frequency generation in a land mobile radio)  
IN SYNTHESIZERS

One of the main uses of a phase locked loop today is to generate discrete known frequencies in a simple manner for use in land mobile radios. It is used to replace the X-tals and associated multipliers, for Transmitter Frequency generation and Receiver local oscillator generation.

It has a number of distinct advantages over a bank of Transmitter and Receiver X-tals. These are:-

- (a) The Synthesizer can generate a very large number of discrete known frequencies.
- (b) It uses only one accurate X-tal as a reference and all frequencies generated by the synthesizer are directly related to this reference X-tal's frequency.
- (c) Digital techniques are used to generate the various frequencies and hence very few tuning elements are required.
- (d) It has a low power consumption if designed using low power digital integrated circuits.
- (e) It can be built small enough to operate in a hand held radio with hundreds of channels.

In a conventional X-tal two way radio, a low frequency X-tal is used followed by a multiplier chain to generate the desired frequency. This is shown in figure 1.

Fig. 1 X-tal Multiplier Chain

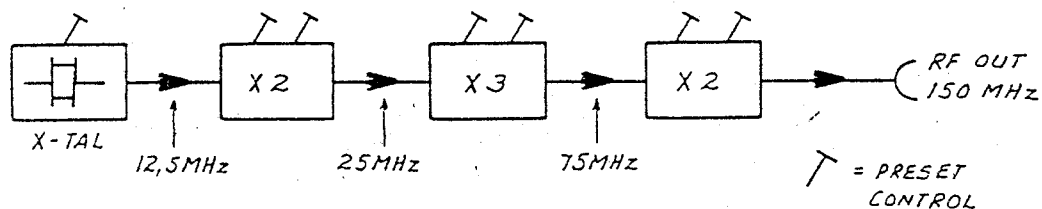

In a synthesizer a high frequency Voltage Controlled Oscillator (VCO) is held on frequency using a Variable Ratio digital frequency Divider (VRD), a phase comparator ( $\phi$ ), and a frequency reference X-tal. This is shown in figure 2.

Fig. 2 Elementary Phase Locked Loop

*Phase detector and multiplier are the same.*

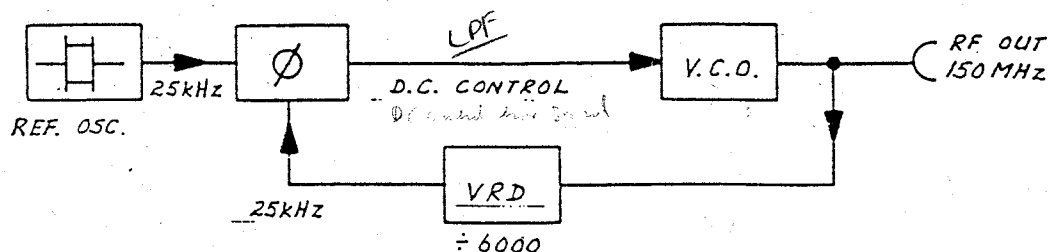

A brief description required for each of the Phase Locked Loop elements is given.

(i) VCO = Voltage Controlled Oscillator

This is an oscillator whose frequency can be changed by varying the DC voltage applied to its control part. Graphically it is described as follows:-

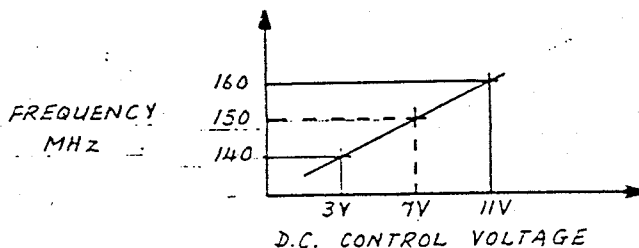

(ii) VRD = Variable Ratio Divider

This is a digital frequency divider made from a number of cascaded flip-flops. It usually takes the form of a number of integrated circuits, and is now also available in a single 20 pin integrated circuit, whose dimensions are approximately 25mm by 7.5mm.

(iii)  $\emptyset$  DET = Phase Detector

The function of a phase detector is to generate a known DC Voltage from two digital signals whose phase (or time arrival) is known, and whose frequencies are identical e.g. if two signals of 25 KHZ are fed into a phase detector directly in phase then the output from this  $\emptyset$  detector could be 7 VDC. However if one of the 25 KHZ signals arrives a fraction of a cycle earlier in time, the output could be 5 VDC. Also true is that if this same 25 KHZ signal arrived a fraction of a cycle later in time, the output could be 9 VDC. Graphically it is described as follows:-

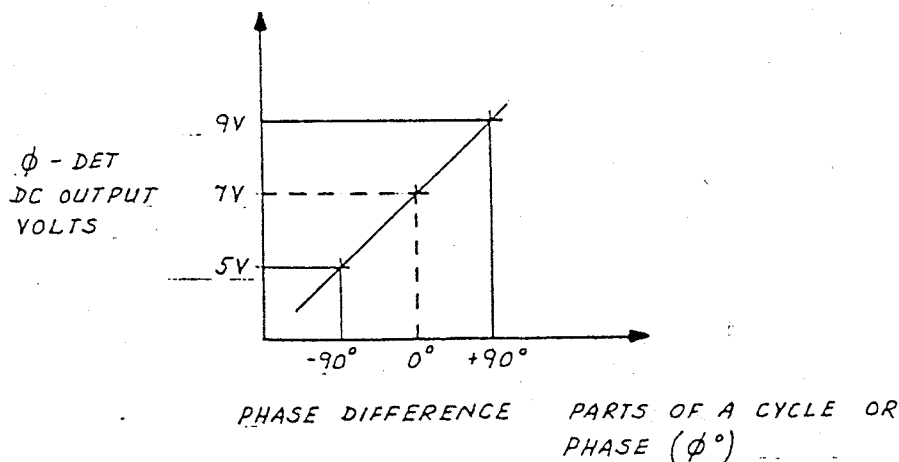

(iv) REF.OSC = Reference Oscillator

This usually takes the form of a X-tal oscillator whose frequency is precisely set to the channel spacing required from the synthesizer e.g. 25 KHZ

Let us now investigate the frequency control action of the phased locked loop of figure 2.

Assume the VCO is oscillating at 150 MHz with its control voltage of 7 volts; and that the VRD is set to divide by 6000. The output from the VRD will then be 25 KHZ. If the reference is 25 KHZ also, then the  $\phi$  detector output voltage will be between 5 V and 9 V dependent upon the phase relationship between these two 25 KHZ signals. Assume they are in phase and that the phase detector gives out 7 volts DC. If the output of the phase detector is now connected to the input of the VCO, then the VCO would remain at 150 MHz.

What happens if the VCO tries to drift to a higher frequency? The output from the VRD would tend to a higher frequency than 25 KHZ i.e. it could be considered that its frequency is advancing or its phase arriving earlier in time than the reference 25 KHZ, or tending to  $-90^\circ$  with respect to the X-tal referenced 25 KHZ signal. The  $\phi$  detector output will then drop its output voltage, and since this is connected to the VCO control input, the VCO frequency will be pulled down to exactly 150 MHz to arrive at a stable loop condition once again. The opposite happens if the VCO tends to drift to a lower frequency. The phase locked loop will force it back to exactly 150 MHz.

The VCO output can easily be changed to any other frequency. This is achieved by changing the division ratio of the VRD. If the VRD is set to divide by 6001, the only stable condition that can be reached is when the VCO runs at 150,025 MHz i.e. one channel up in frequency or an increment increase equal to the reference 25 KHZ.

The synthesizer shown in figure 2 requires many refinements before it can be used successfully in a land mobile radio.

Firstly a 25 KHZ X-tal is large and fragile. Stable low ageing X-tals with a low temperature coefficient, which are robust and small are only available at about 5 MHz. It can be used in the synthesizer together with a fixed ratio frequency divider to generate 25 KHZ. This is shown in figure 3.

Figure 3 Frequency reference 25 KHZ generated from a 5 MHz X-tal

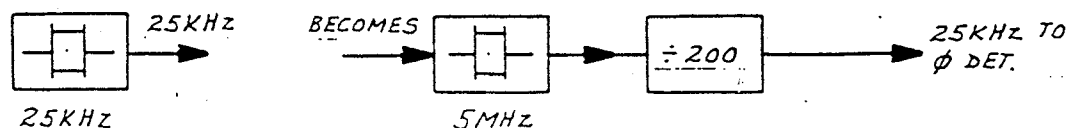

Secondly the output of the phase detector is not a pure DC signal in practice. It has components of the reference frequency. If these spurious signals are present at the input of the VCO control point, spurious 25 KHZ sidebands from the VCO will be created. This will result in a synthesizer with bad spectral purity, resulting in a radio with poor adjacent channel performance. It is possible to remove the 25 KHZ components generated by the  $\phi$  detector before they enter the VCO by incorporating a low pass filter in the design. See figure 4.

Figure 4 Low Pass Filter incorporated in a  $\phi$  locked loop

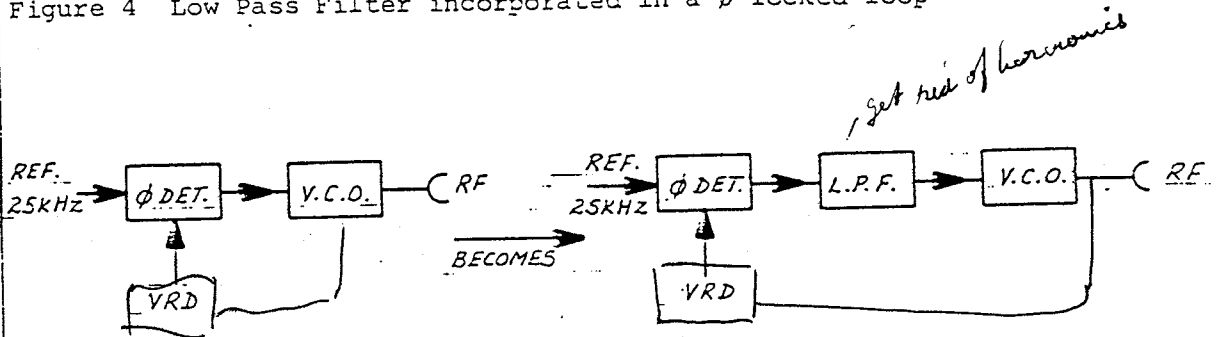

Thirdly the Variable Ratio Divided is difficult to access directly from a normal channel selector switch. Furthermore, the operator of the radio must be permitted to use only those channels allocated on the license issued by the Postal Authorities. Both of these problems can be overcome by using a PROM - Programmable Read Only Memory. Such a device is available in a small digital integrated circuit similar in size to the single chip VRD mentioned previously. A PROM consists of a myriad of tiny fuses, and by "blowing" some of the fuses to a defined pattern, the frequencies to be generated by the synthesizer can be stored in the PROM permanently, and furthermore, these codes can easily be addressed by a simple binary coded channel switch. This interface is shown in figure 5.

Figure 5 PROM incorporated in the phase locked loop

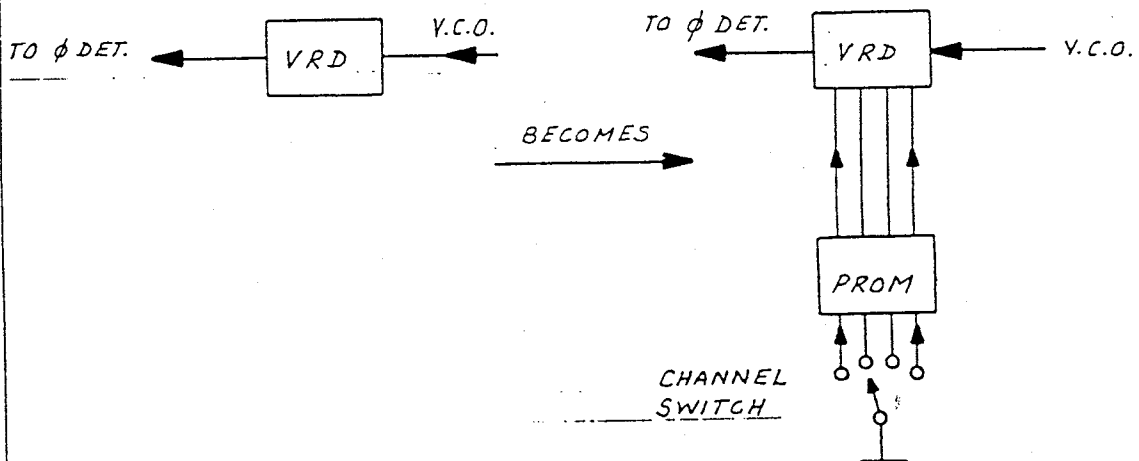

Fourthly the Variable Ratio Divider if built using discrete semiconductors or even discrete integrated circuits is extremely complex and "power hungry" since it has to operate at very high frequencies. A clever technique recently developed uses a "fast stupid divider" controlled by a "slow clever divider". This is shown in figure 6.

Figure 6 The 40/41 divider used in the synthesizer

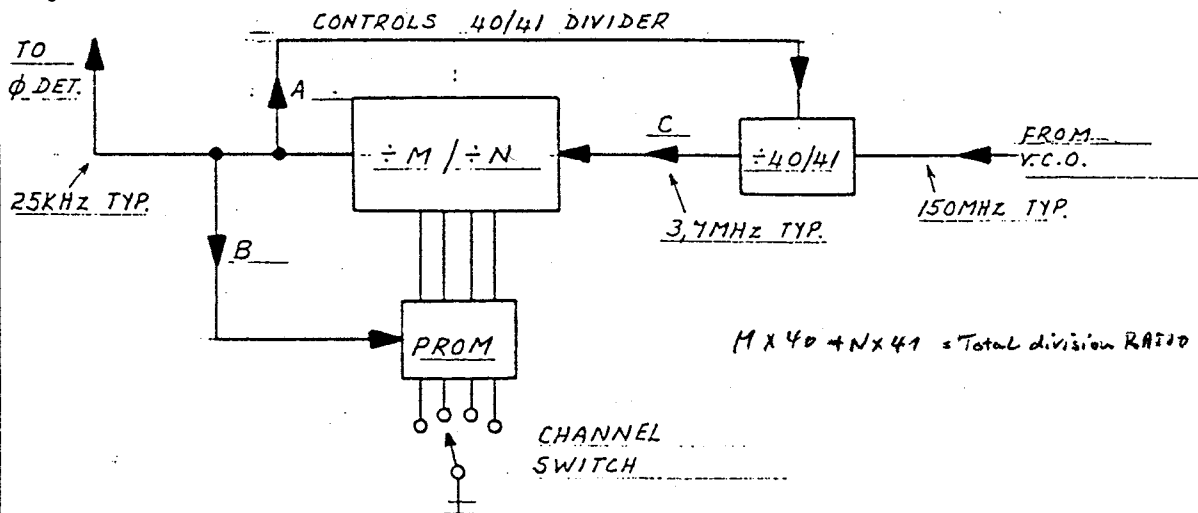

The 40/41 divider is the "fast stupid" divider. It can only divide by two numbers, either 40 or 41. Because of this feature its circuitry, which operates at high speed, is limited and consumes low power.

The  $\div M / \div N$  divider is the "slow clever" divider. It can divide by almost any number for M and N and hence has complete circuitry. It however only has to operate at an input frequency of 3,7 MHz and hence also consumes very little power.

The M/N divider ratio is controlled by the PROM and also the signal to the  $\phi$  detector. M and N are two independently controlled numbers, both of which are stored in the PROM. The PROM controls the count of N and the count of M, without having to change the channel number. The 40/41 divider is simultaneously controlled by the signal for the  $\phi$  detector.

The total division ratio of the VRD is thus:-

$$M \text{ rounds of } 40 + N \text{ rounds of } 41 = \text{Total Division Ratio}$$

$$\text{e.g. } (68 \times 40) + (80 \times 41) = 6000 \quad (\text{VCO} = 150 \text{ MHz})$$

$$\text{e.g. } (67 \times 40) + (81 \times 41) = 6001 \quad (\text{VCO} = 150,025 \text{ MHz})$$

In the above examples M = 68, N = 80 for VCO = 150 MHz

M = 67, N = 81 for VCO = 150,025 MHz

The overall synthesizer, in a useful form is shown in figure 7.

Figure 7 Frequency Synthesizer for a Land Mobile Radio

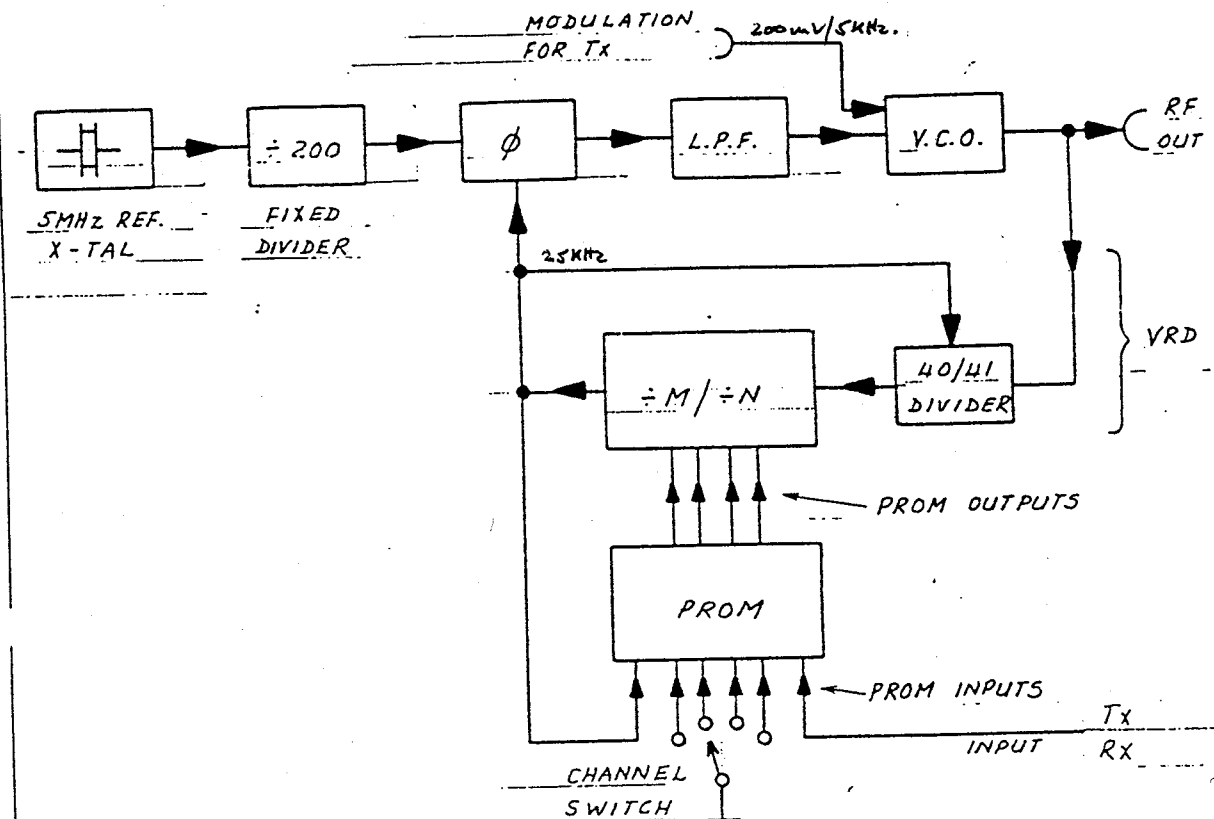

Two further refinements have been incorporated in the above complete block diagram. A TX/RX input has been added as an additional PROM input. This allows the synthesizer to create different frequencies for TX and RX modes. A modulation input has also been added to the VCO. This input is only used during transmit and is a simple way of modulating the VCO for use in FM systems.

The elements of frequency synthesis have been explained. These techniques are used in the Servitek land mobile radios in both the hand held and mobile versions. There are other methods of frequency synthesis, but as in most systems, the design must be adapted to best suit its application. A further refinement which is mostly incorporated in frequency synthesizer but which is not shown in figure 7 is an AFC (automatic frequency control) circuit. The function of the AFC is to pretune the VCO close to the desired operating frequency to a degree sufficient for the loop to capture the correct operating frequency.

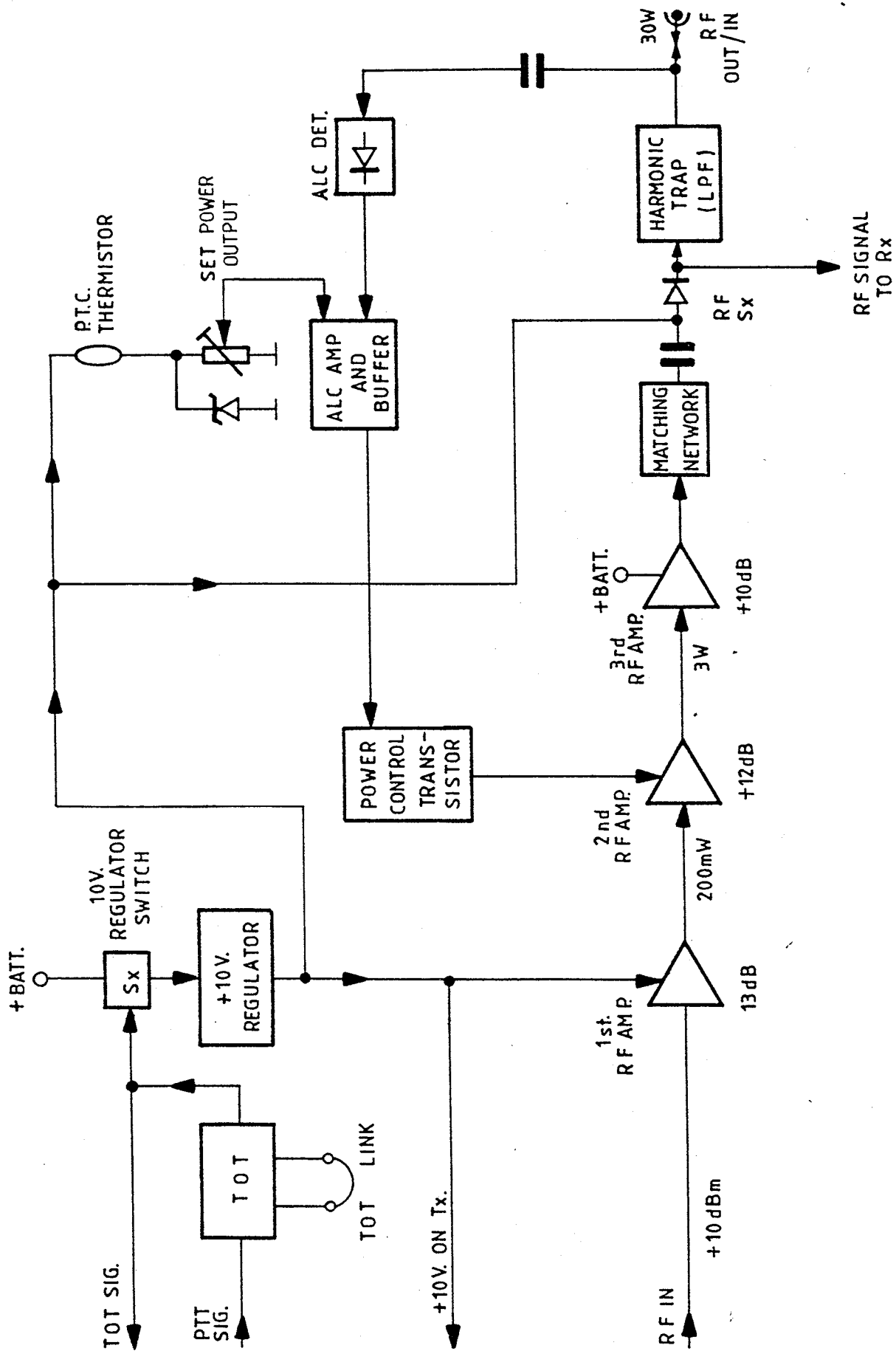

ISSUE	1		
DATE	5/88		

BLOCK DIAGRAM

DOC. No. UAJ00-029DBD

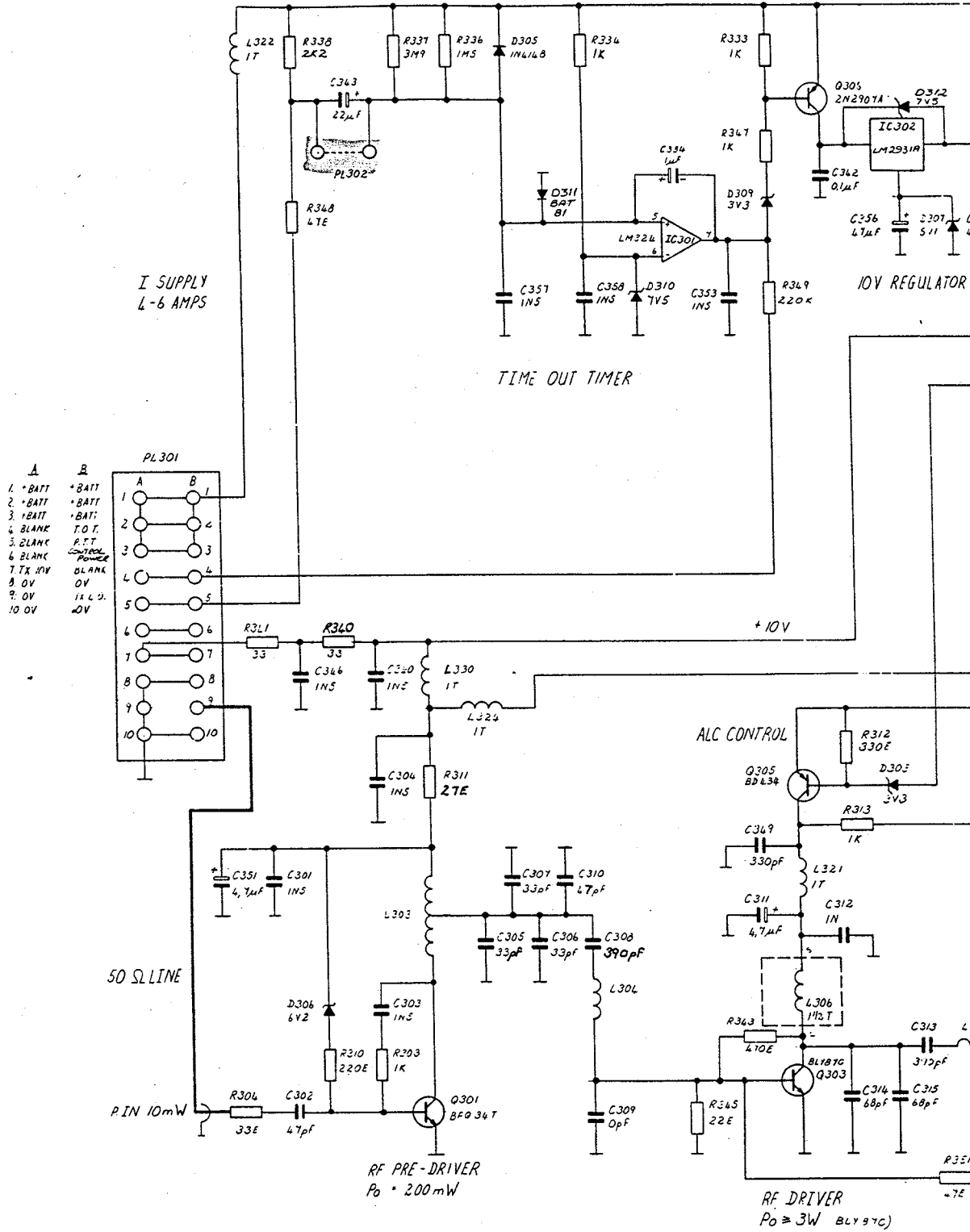

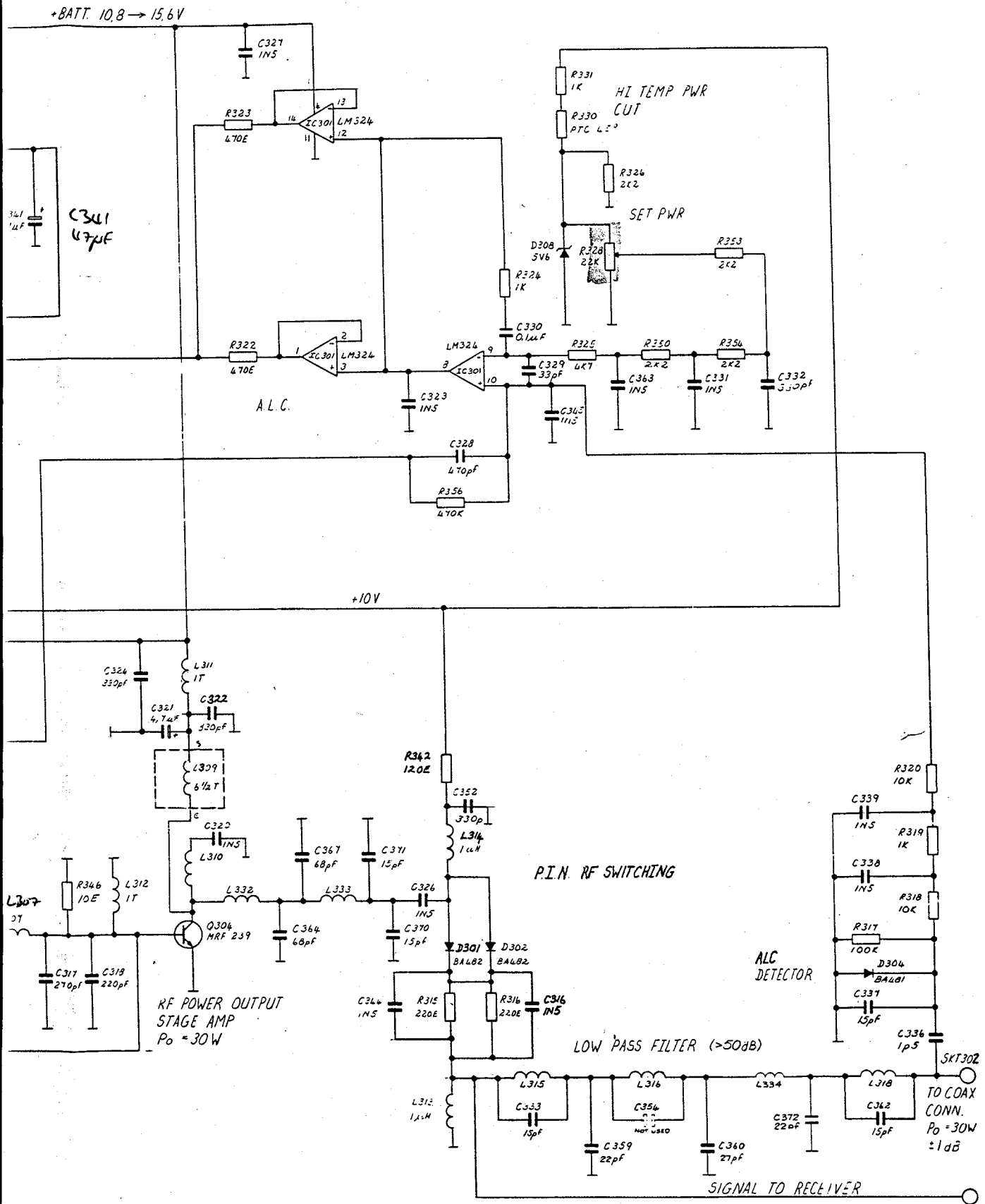

6

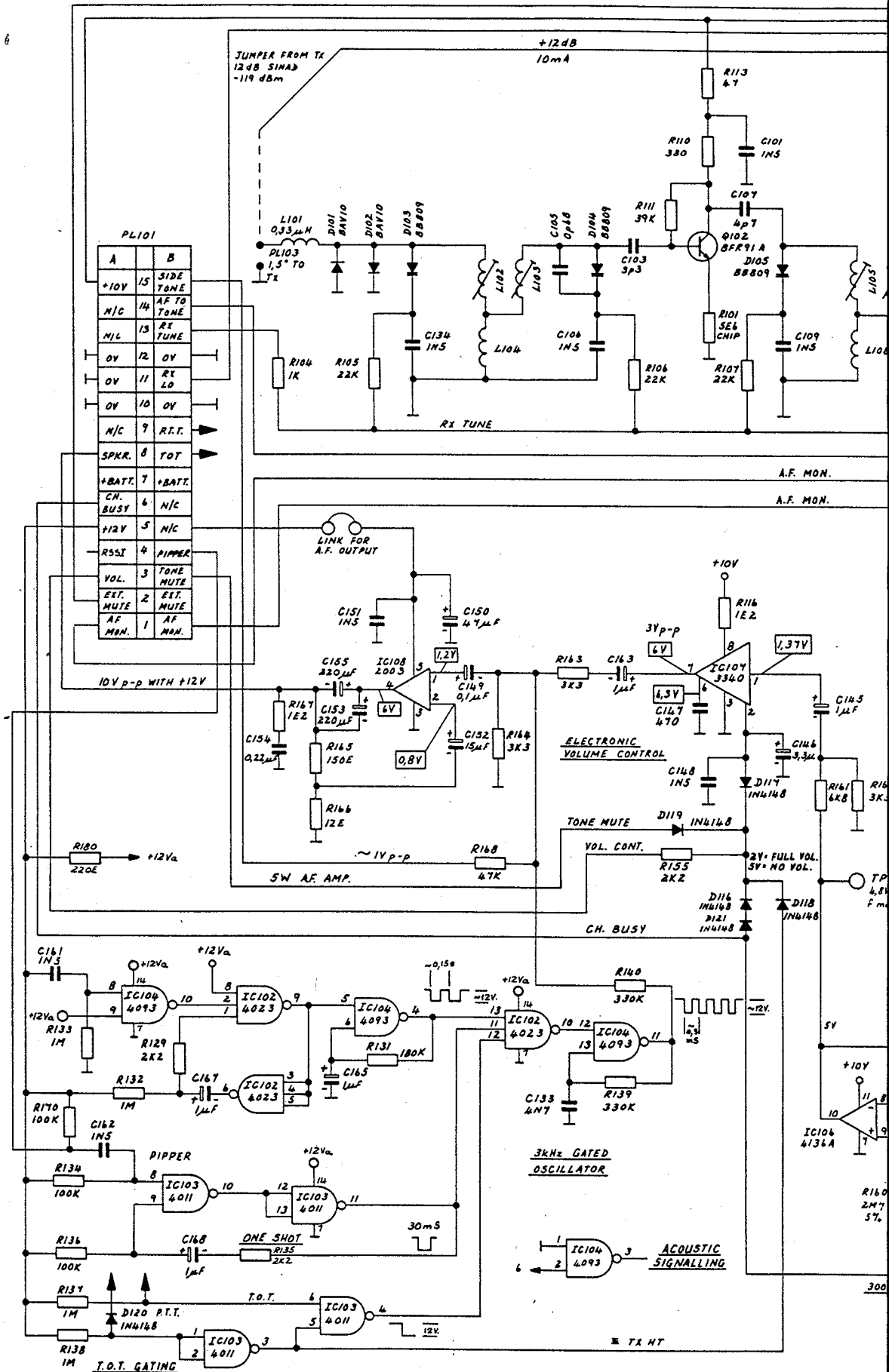

ISSUE	1		
DATE	5/88		

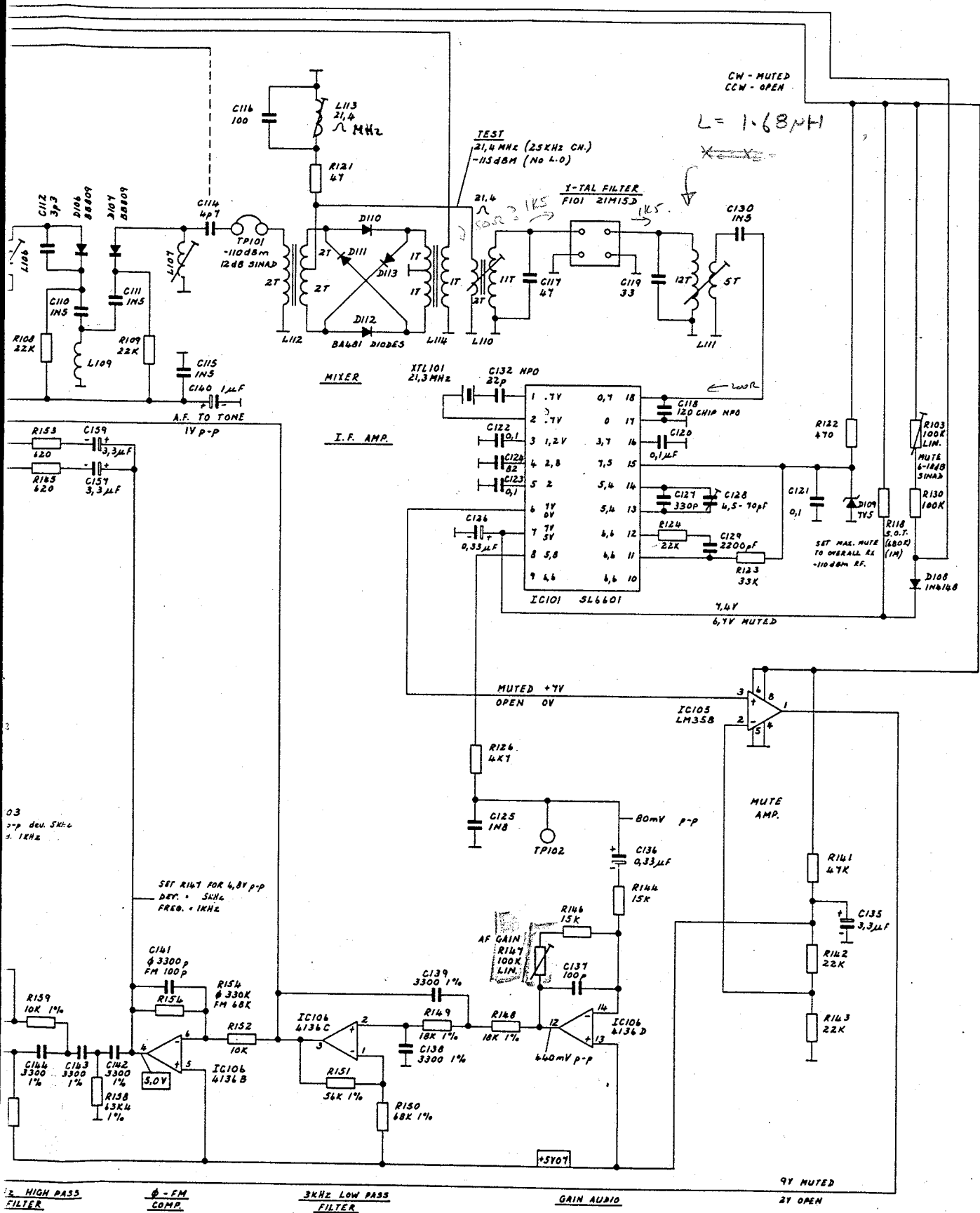

2. HIGH PASS FILTER      4. FM COMP.      3KHZ LOW PASS FILTER      GAIN AUDIO      9V MUTED 2V OPEN

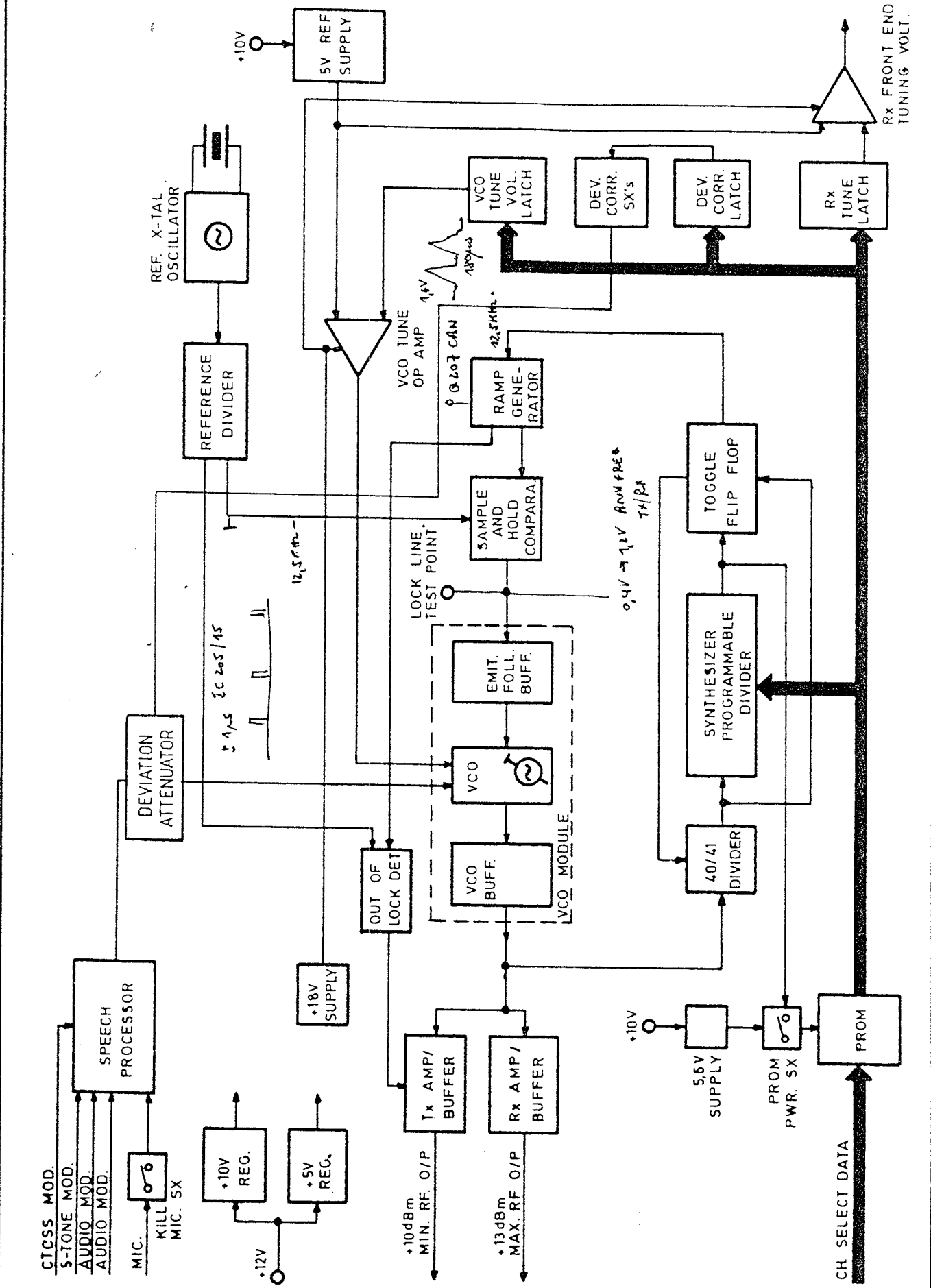

ISSUE	1
DATE	5/88

BLOCK DIAGRAM

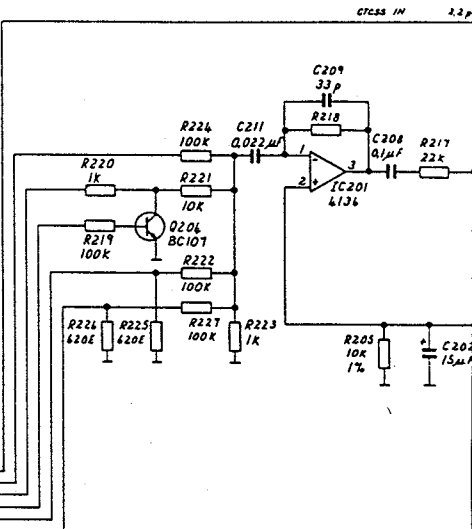
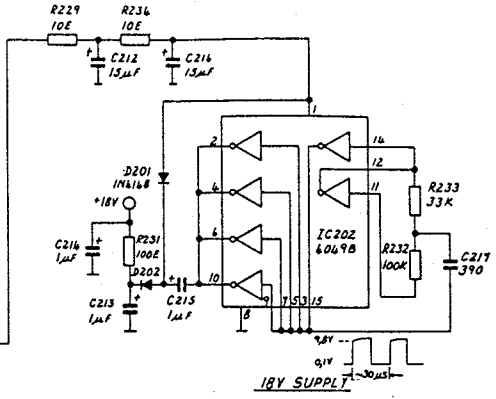
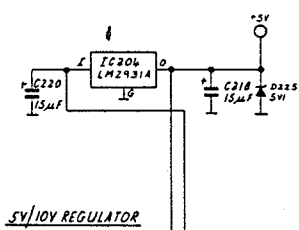

PL201

	A	B
1	OV	OV
2	Tx LPA	OV
3	OV	OV
4	Rx LPA	OV
5	OV	OV
6	RT	TUNE
7	MIC IN	Tx 10V
8	MOD ST	MOD ST
9	KILL MIC	MIC
10	CFSS	CFSS
11	+10V	CH 12
12	CH 16	+12V
13	CH 11	CH 18
14	CH 12	CH 10
15	MOD AF	MOD AF

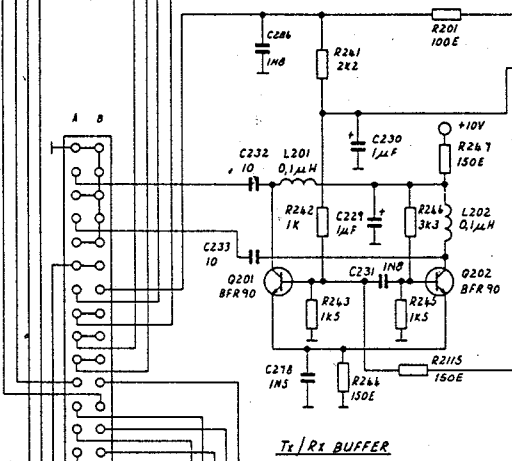

3.2 p/p @ 750 Hz dev  
+5V 350Hz DEV.

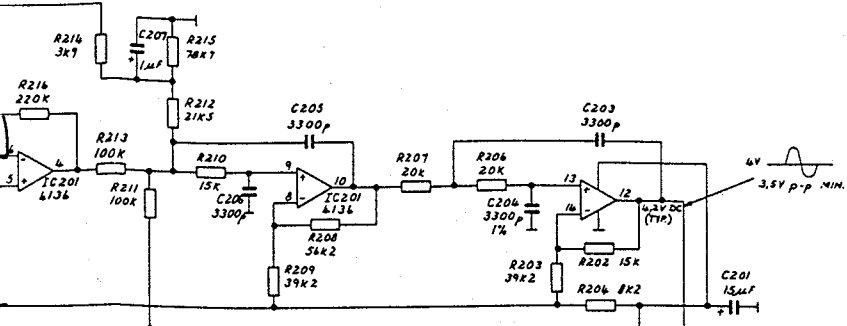

**SPEECH PROCESSOR**

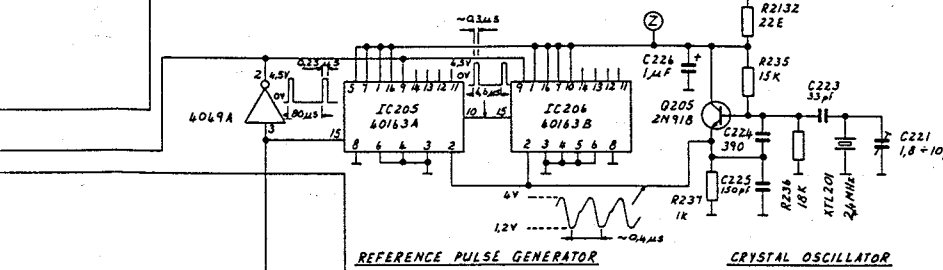

**REFERENCE PULSE GENERATOR**      **CRYSTAL OSCILLATOR**

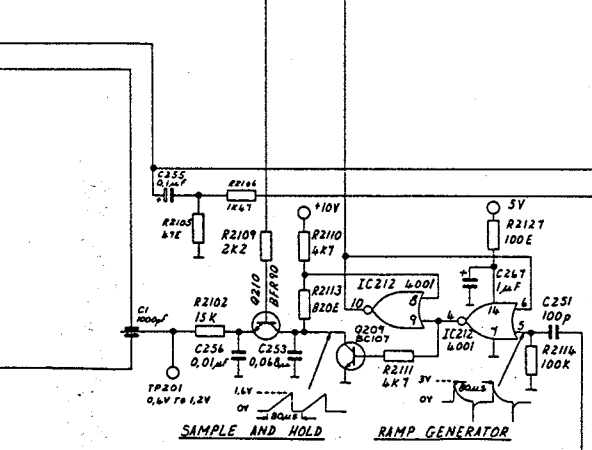

**SYNTHESIZER AFC**

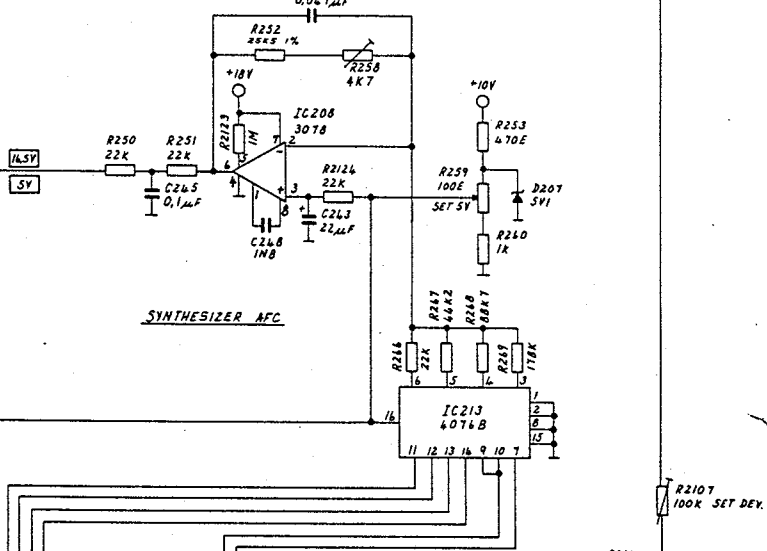

**SYNTHESIZER DIVIDERS**

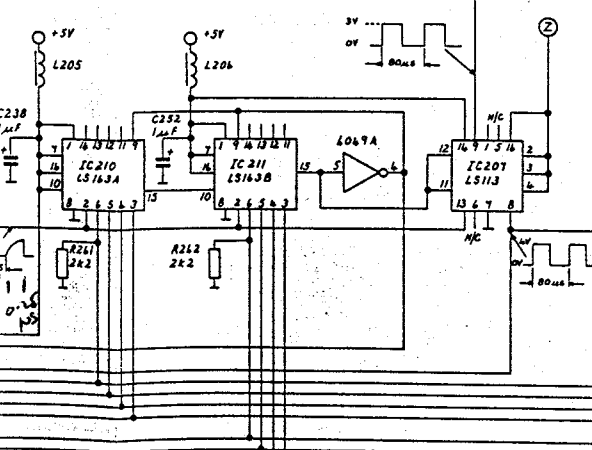

**Tx TUNE**

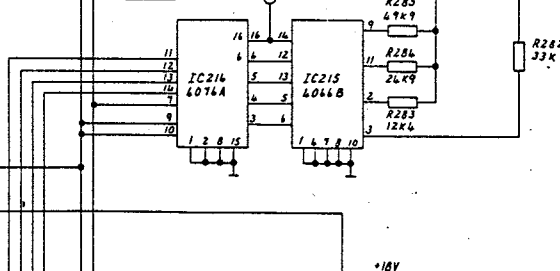

**Rx TUNE**

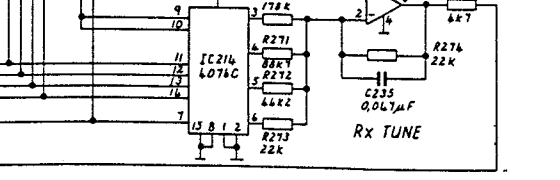

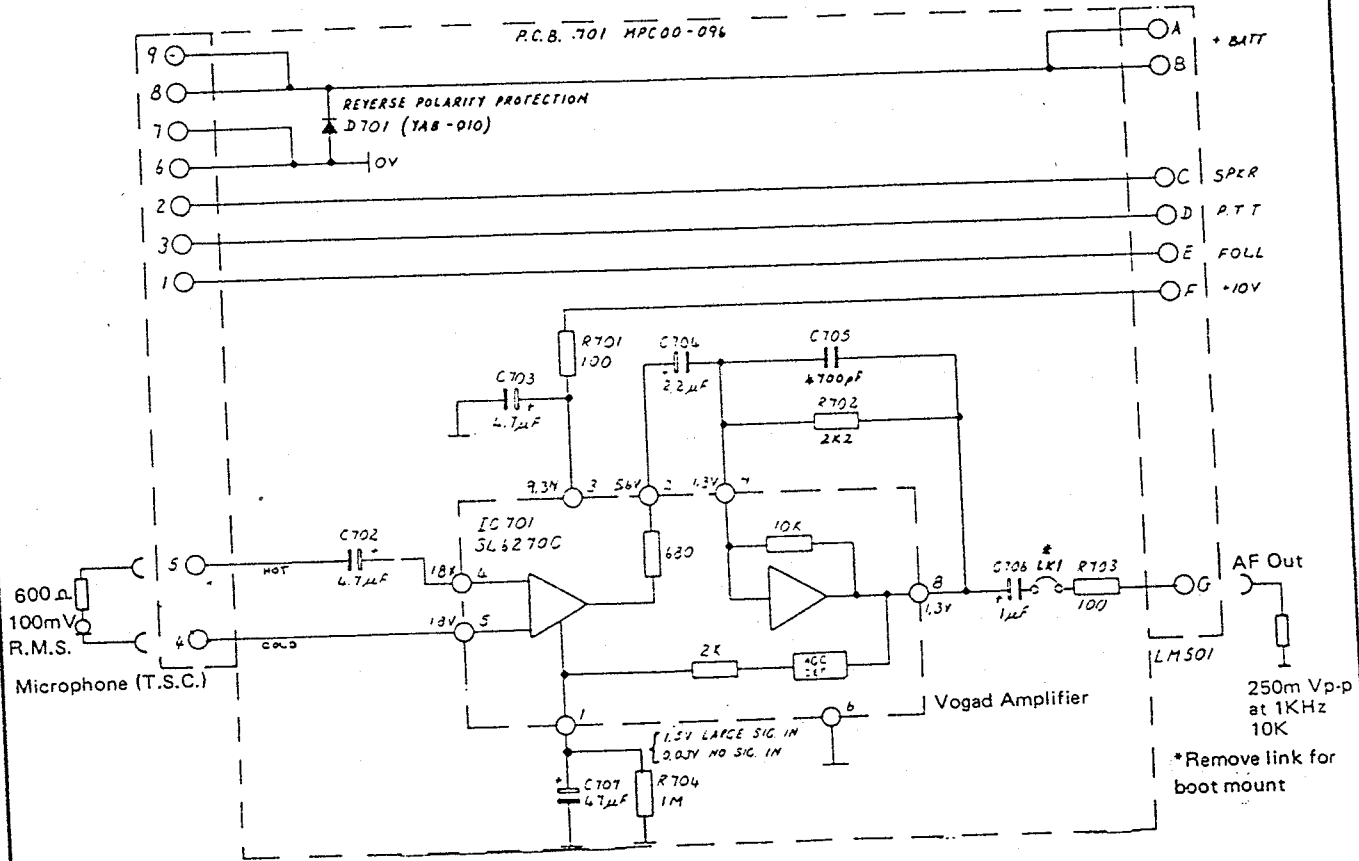

NOTE:  
For testing connect a 2.2  $\mu$ F 6V capacitor between PL701 Pin 4 (+VE) and PL701 Pin 6 (-VE)  
Inject signal sine wave at 1KHz between PL701 Pin 5 and 6 (earth).

ISSUE	1		
DATE	5/88		

CIRCUIT DIAGRAM  
MICROPHONE AMPLIFIER

DOC. No. UAU00-002DCI