

SERVICE DATA AND SPECIFICATIONS (SDS)

RD

Engine Lubrication System

Oil pressure check

Engine rpm	Approximate discharge pressure kPa (bar, kg/cm ² , psi)
Idle speed 3,000	More than 78 (0.78, 0.8, 11) 318.7 - 424.8 (3.18 - 4.25, 3.25 - 4.33, 46.2 - 61.6)

Oil pump

Unit: mm (in)

Body to outer gear clearance ①	0.11 - 0.20 (0.0043 - 0.0078)
Inner gear to crescent clearance ②	0.216 - 0.328 (0.0085 - 0.0128)
Outer gear to crescent clearance ③	0.21 - 0.32 (0.0083 - 0.0126)
Housing to inner gear clearance ④	0.05 - 0.09 (0.0020 - 0.0035)
Housing to outer gear clearance ⑤	0.05 - 0.11 (0.0020 - 0.0043)
Inner gear to brazed portion of housing clearance ⑥	0.106 - 0.152 (0.0042 - 0.0060)

Engine Cooling System

Thermostat

Valve opening temperature	C° (°F)	82.0 (180)
Maximum valve lift	mm/°C (in/°F)	10/95 (0.39/203)

Radiator

Unit: kPa (bar, kg/cm², psi)

Cap relief pressure	78 - 98 (0.78 - 0.98, 0.8 - 1.0, 11 - 14)
Leakage test pressure	157 (1.57, 1.6, 23)

QI
MA
EM
LC
EC
FE
CL
MT
AT
TF
PD
FA
RA
BR
ST
RS
BT
HA
EL
SE
IDX

SERVICE DATA AND SPECIFICATIONS (SDS)

RD

General Specifications

Cylinder arrangement		In-line 6
Displacement	cm ³ (cu in)	2,828 (172.44)
Bore and stroke	mm (in)	85 x 83 (3.35 x 3.27)
Valve arrangement		OHC
Firing order		1-6-3-5-2-4
Number of piston rings		
Compression		2
Oil		1
Number of main bearings		7
Compression ratio		21.8

VALVE TIMING

Without warm-up three way catalyst

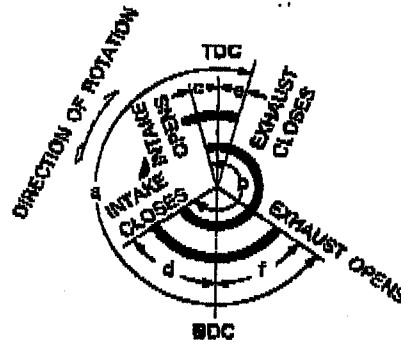

EM120
Unit: degree

a	b	c	d	e	f
248	220	7	33	8	60

Inspection and Adjustment

COMPRESSION PRESSURE

Unit: kPa (bar, kg/cm², psi)/200 rpm

Compression pressure		
Standard		3,040 (30.4, 31, 441)
Minimum		2,452 (24.5, 25, 358)
Differential limit between cylinders		490 (4.9, 5, 71)

CYLINDER HEAD

Unit: mm (in)

	Standard	Limit
Head surface distortion	Less than 0,03 (0.0012)	0.1 (0.004)

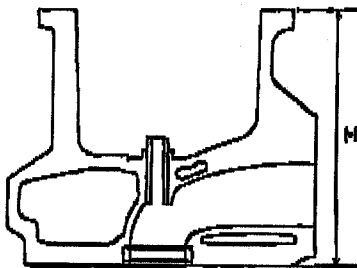

SEM795F

Nominal cylinder head height "H"	139.9 - 140.1 (5.508 - 5.518)
Resurfacing limit	0.1 (0.004)

SERVICE DATA AND SPECIFICATIONS (SDS)

RD

Inspection and Adjustment (Cont'd)

VALVE

Unit: mm (in)

T (Margin thickness)

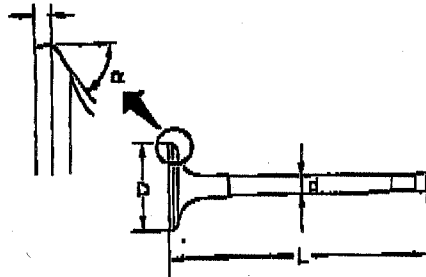

SEM188A

Valve head diameter "D"	
Intake	39.0 - 39.3 (1.535 - 1.547)
Exhaust	32.0 - 32.3 (1.260 - 1.272)
Valve length "L"	
Intake	101.53 - 101.97 (3.9972 - 4.0146)
Exhaust	101.38 - 101.82 (3.9913 - 4.0087)
Valve stem diameter "d"	
Intake	6.985 - 6.990 (0.2742 - 0.2748)
Exhaust	6.945 - 6.960 (0.2734 - 0.2740)
Valve seat angle "α"	
Intake	45°15' - 45°45'
Exhaust	
Valve margin "T"	
Intake	1.35 - 1.65 (0.0531 - 0.0650)
Exhaust	1.65 - 1.95 (0.0650 - 0.0768)
Valve margin "T" limit	
	More than 0.5 (0.020)
Valve stem end surface grinding limit	
	Less than 0.2 (0.008)

Valve lifter

Unit: mm (in)

Valve lifter diameter	34.960 - 34.975 (1.3764 - 1.3770)
Lifter guide hole diameter	34.998 - 35.018 (1.3779 - 1.3787)
Clearance between lifter and lifter guide hole	0.023 - 0.058 (0.0009 - 0.0023)

Valve guide

Unit: mm (in)

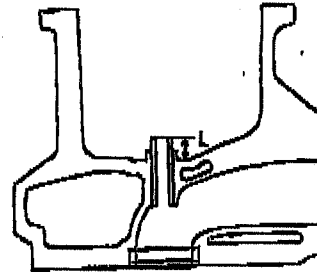

SEM796F

		Standard	Service
Valve guide			
Outer diameter	Intake	11.028 - 11.034 (0.4340 - 0.4344)	11.233 - 11.234 (0.4422 - 0.4423)
	Exhaust	11.028 - 11.034 (0.4340 - 0.4344)	11.233 - 11.234 (0.4422 - 0.4423)
Valve guide			
Inner diameter (Finished size)	Intake	7.000 - 7.016 (0.2756 - 0.2763)	
	Exhaust	7.000 - 7.016 (0.2756 - 0.2763)	
Cylinder head valve guide hole diameter	Intake	10.975 - 10.988 (0.4321 - 0.4328)	11.185 - 11.196 (0.4404 - 0.4408)
	Exhaust	10.975 - 10.986 (0.4321 - 0.4328)	11.185 - 11.196 (0.4404 - 0.4408)
Interference fit of valve guide		0.027 - 0.059 (0.0011 - 0.0023)	
		Standard	Limit
Stem to guide clearance	Intake	0.020 - 0.050 (0.0008 - 0.0020)	0.1 (0.004)
	Exhaust	0.040 - 0.070 (0.0016 - 0.0028)	0.1 (0.004)
Valve deflection limit		0.2 (0.008)	
Projection length "L"		10.2 - 10.4 (0.402 - 0.409)	

SERVICE DATA AND SPECIFICATIONS (SDS)

RD

Inspection and Adjustment (Cont'd)

Valve seat

Unit: mm (in)

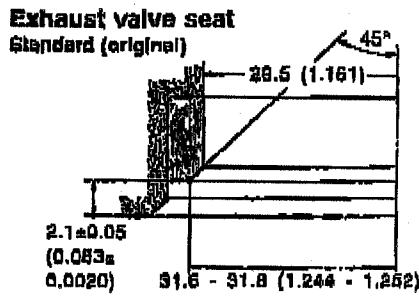

SEM788BA

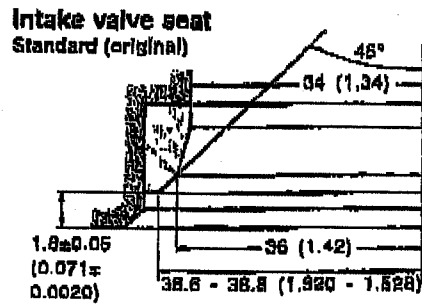

SEM773BA

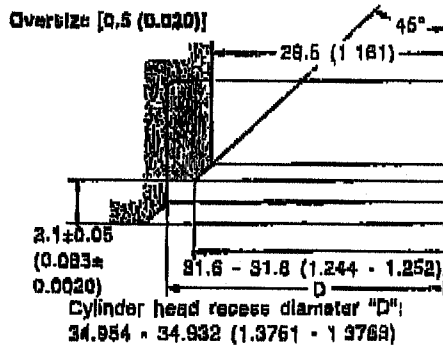

SEM790BA

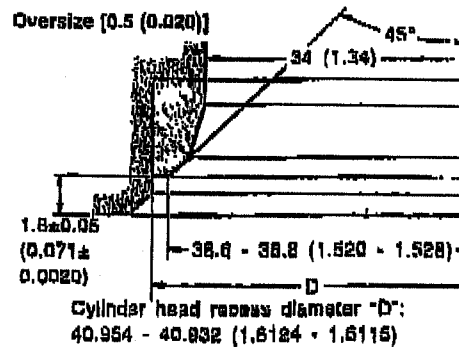

SEM788BA

Cylinder head to valve distance

Unit: mm (in)

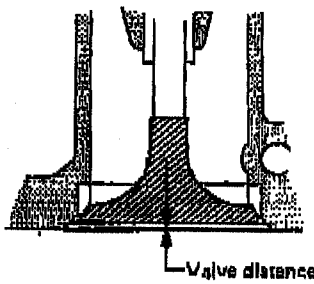

SEM724C

	Standard
Intake	-0.089 to 0.289 (-0.0027 to 0.0106)
Exhaust	-0.089 to 0.289 (-0.0027 to 0.0106)

Valve spring

Free height	mm (in)
Outer	42.25 (1.6634)
Inner	35.57 (1.4098)
Pressure height/Load	mm/N (mm/kg, in/lb)
Outer	25.7/437.69 (25.7/44.63, 1.012/99.41)
Inner	22.2/233.21 (22.2/23.78, 0.874/52.43)
Out-of-square	mm (in)
Outer	1.8 (0.075)
Inner	1.6 (0.063)

SERVICE DATA AND SPECIFICATIONS (SDS)

RD

Inspection and Adjustment (Cont'd)

Available shim

Thickness mm (in)	Identification mark
2.80 (0.1142)	2.80
2.85 (0.1122)	2.85
2.80 (0.1102)	2.80
2.75 (0.1083)	2.75
2.70 (0.1063)	2.70
2.65 (0.1043)	2.65
2.60 (0.1024)	2.60
2.55 (0.1004)	2.55
2.50 (0.9844)	2.50
2.45 (0.9665)	2.45
2.40 (0.9485)	2.40
2.35 (0.9325)	2.35
2.30 (0.9108)	2.30
2.25 (0.8885)	2.25
2.20 (0.8665)	2.20

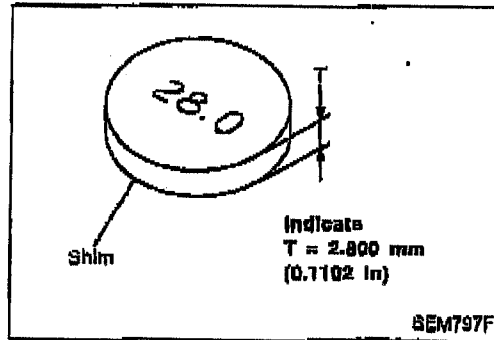

Valve clearance

	Unit: mm (in)	
	For adjusting	
	Hot	Cold*
Intake	0.26 - 0.35 (0.011 - 0.015)	0.26 - 0.34 (0.010 - 0.013)
Exhaust	0.32 - 0.42 (0.013 - 0.017)	0.30 - 0.38 (0.012 - 0.015)

* At a temperature of approximately 20°C (68°F)

Whenever valve clearances are adjusted to cold specifications, check that the clearances satisfy hot specifications and adjust again if necessary.

CAMSHAFT AND CAMSHAFT BEARING

	Unit: mm (in)	
	Standard	Limit
Camshaft journal to bearing clearance	0.045 - 0.086 (0.0018 - 0.0034)	0.1 (0.004)
Inner diameter of camshaft bearing	30.000 - 30.021 (1.1811 - 1.1819)	—
Outer diameter of camshaft journal	29.935 - 29.955 (1.1785 - 1.1799)	—
Camshaft runout (TIR*)	—	0.02 (0.0008)
Camshaft sprocket runout (TIR*)	Less than 0.25 (0.0098)	—
Camshaft end play	0.065 - 0.169 (0.0026 - 0.0067)	0.20 (0.0079)

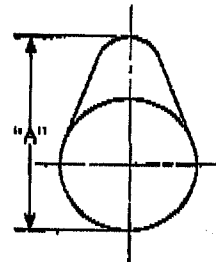

Cam height "A"	
Intake	46.005 - 46.195 (1.8900 - 1.8574)
Exhaust	49.505 - 49.695 (1.9490 - 1.9565)
Wear limit of cam height	0.16 (0.0063)
Valve lift	
Intake	8.27 (0.326)
Exhaust	9.43 (0.371)

* Total indicator reading

GI
MA
EM
LC
EC
FE
CL
MT
AT
TF
PD
FA
RA
BR
ST
RS
BT
HA
EL
SE
IDX

SERVICE DATA AND SPECIFICATIONS (SDS)

RD

Inspection and Adjustment (Cont'd)

CYLINDER BLOCK

Unit: mm (in)

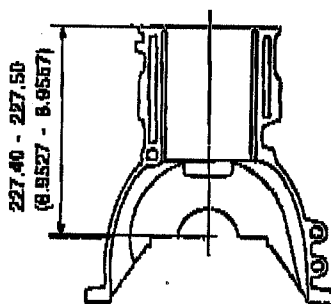

SEM864EA

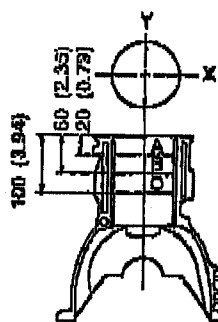

SEM866DA

Surface flatness	
Standard	Less than 0.03 (0.0012)
Limit	0.1 (0.004)
Cylinder bore	
Inner diameter	
Standard	
Grade No. 1	85.000 - 85.010 (3.3466 - 3.3466)
Grade No. 2	85.010 - 85.020 (3.3468 - 3.3472)
Grade No. 3	85.020 - 85.030 (3.3472 - 3.3476)
Wear limit	0.20 (0.0079)
Out-of-round (X - Y)	
Standard	Less than 0.016 (0.0006)
Taper (A - B and A - C)	
Standard	Less than 0.010 (0.0004)
Differences in inner diameter between cylinders	
Limit	Less than 0.05 (0.0020)
Main journal inner diameter	
Grade No. 0	58.645 - 58.654 (2.3085 - 2.3092)
Grade No. 1	58.654 - 58.663 (2.3092 - 2.3096)
Grade No. 2	58.663 - 58.672 (2.3096 - 2.3099)

PISTON, PISTON RING AND PISTON PIN

Piston

Unit: mm (in)

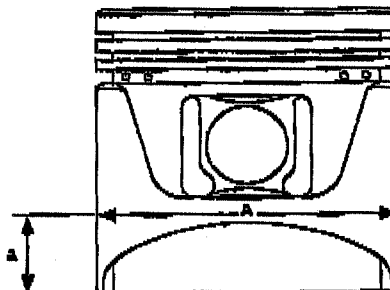

SEM760C

Piston skirt diameter "A"	
Standard	
Grade No. 1	84.960 - 84.970 (3.3449 - 3.3455)
Grade No. 2	84.970 - 84.980 (3.3453 - 3.3457)
Grade No. 3	84.980 - 84.990 (3.3457 - 3.3461)
0.50 (0.0197) over-size (Service)	85.460 - 85.480 (3.3646 - 3.3657)
1.00 (0.0394) over-size (Service)	85.960 - 85.980 (3.3842 - 3.3854)
"a" dimension	14.5 (0.571)
Piston clearance to cylinder block	0.030 - 0.050 (0.0012 - 0.0020)
Piston pin hole diameter	26.985 - 27.005 (1.0628 - 1.0632)

SERVICE DATA AND SPECIFICATIONS (SDS)

RD

Piston ring

Inspection and Adjustment (Cont'd)

CONNECTING ROD

		Unit: mm (in)
Side clearance		
Top		
Standard	0.060 - 0.093 (0.0024 - 0.0037)	
Limit	0.1 (0.004)	
2nd		
Standard	0.040 - 0.073 (0.0016 - 0.0029)	
Limit	0.1 (0.004)	
Oil		
Standard	0.030 - 0.063 (0.0012 - 0.0025)	
Limit	—	
Ring gap		
Top		
Standard	0.20 - 0.28 (0.0079 - 0.0110)	
Limit	1.0 (0.039)	
2nd		
Standard	0.38 - 0.53 (0.0150 - 0.0209)	
Limit	1.0 (0.039)	
Oil		
Standard	0.30 - 0.66 (0.0118 - 0.0220)	
Limit	1.0 (0.039)	

		Unit: mm (in)
Center distance	140.0 (5.512)	
Bend [per 100 (3.94)]		
Limit	0.025 (0.0010)	
Torsion [per 100 (3.94)]		
Limit	0.025 (0.0010)	
Connecting rod small end inner diameter	30.000 - 30.013 (1.1811 - 1.1816)	
Piston pin bushing inner diameter*	27.025 - 27.038 (1.0640 - 1.0645)	
Connecting rod big end inner diameter		
Grade No. 0	53.000 - 53.007 (2.0868 - 2.0869)	
Grade No. 1	53.007 - 53.013 (2.0869 - 2.0871)	
Side clearance		
Standard	0.20 - 0.30 (0.0079 - 0.0118)	
Limit	0.40 (0.0157)	

* After installing in connecting rod

Piston pin

		Unit: mm (in)
Piston pin outer diameter	26.994 - 27.000 (1.0628 - 1.0630)	
Interference fit of piston pin to piston	0.002 - 0.008 (0.0001 - 0.0002)	
Piston pin to connecting rod bushing clearance		
Standard	0.025 - 0.044 (0.0010 - 0.0017)	

* Values measured at ambient temperature of 20°C (68°F)

GI
MA
EM
LC
EC
FE
CL
MT
AT
TF
PD
FA
RA
BR
ST
RS
BT
HA
EL
SE
IDX

SERVICE DATA AND SPECIFICATIONS (SDS)

RD

CRANKSHAFT

Unit: mm (In)

Main journal dia. "Dm"	
Grade No. 0	54.957 - 54.975 (2.1641 - 2.1644)
Grade No. 1	54.959 - 54.967 (2.1637 - 2.1641)
Grade No. 2	54.951 - 54.959 (2.1634 - 2.1637)
Pin journal dia. "Dp"	
Grade No. 0	49.968 - 49.974 (1.9672 - 1.9675)
Grade No. 1	49.961 - 49.968 (1.9670 - 1.9672)
Center distance "r"	
	41.47 - 41.53 (1.6327 - 1.6350)
Out-of-round (X - Y)	
Standard	Main journal Less than 0.005 (0.0002) Pin journal Less than 0.0025 (0.0001)
Taper (A - B)	
Standard	Main journal Less than 0.005 (0.0002) Pin journal Less than 0.0025 (0.0001)
Runout [TIR]	
Standard	Less than 0.025 (0.0010)
Limit	Less than 0.05 (0.0020)
Free end play	
Standard	0.05 - 0.15 (0.0020 - 0.0071)
Limit	0.30 (0.0118)

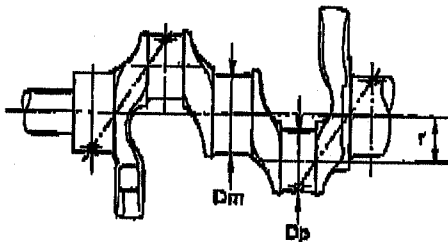

SEM646

Out-of-round (X - Y)
Taper (A - B)

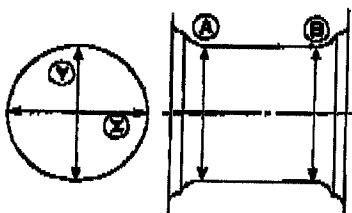

EM718

Inspection and Adjustment (Cont'd)
MAIN BEARING

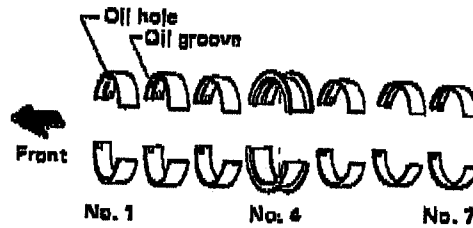

SEM1875

Standard

Unit: mm (In)

Grade number	Thickness "T"	Width "W"	Identification color
0	1.813 - 1.817 (0.0714 - 0.0715)	19.7 - 19.8 (0.776 - 0.783)	Black
1	1.817 - 1.821 (0.0715 - 0.0717)		Brown
2	1.821 - 1.825 (0.0717 - 0.0718)		—
3	1.825 - 1.829 (0.0719 - 0.0720)		Yellow
4	1.829 - 1.833 (0.0720 - 0.0722)		Blue

Undersize

Unit: mm (In)

Undersize	Thickness "T"	Main journal diameter "Dm"
0.25 (0.0098)	2.109 - 2.117 (0.0830 - 0.0833)	Grind so that bearing clearance is the specified value.

CONNECTING ROD BEARING

Connecting rod bearing
Standard size

Unit: mm (In)

Grade number	Thickness "T"	Width "W"	Identification color
0	1.488 - 1.496 (0.0587 - 0.0589)	19.8 - 20.1 (0.783 - 0.791)	Black
1	1.496 - 1.500 (0.0590 - 0.0591)		Yellow
2	1.500 - 1.504 (0.0591 - 0.0592)		Brown

SERVICE DATA AND SPECIFICATIONS (SDS)

RD

Inspection and Adjustment (Cont'd)

Undersize

Unit: mm (in)

Undersize	Thickness "T"	Crank pin journal diameter "Dp"
0,08 (0,0031)	1,538 - 1,540 (0,0605 - 0,0608)	Grind so that bearing clearance is the specified value.
0,12 (0,0047)	1,556 - 1,560 (0,0613 - 0,0614)	
0,25 (0,0098)	1,621 - 1,625 (0,0638 - 0,0640)	

MISCELLANEOUS COMPONENTS

Unit: mm (in)

Camshaft sprocket runout limit (TIR)	0.1 (0.004)
Flywheel runout limit (TIR)	0.1 (0.004)
Drive plate runout limit (TIR)	0.1 (0.004)

Bearing clearance

Unit: mm (in)

Main bearing clearance	
Standard	0,038 - 0,063 (0,0014 - 0,0025)
Limit	0,12 (0,0047)
Connecting rod bearing clearance	
Standard	0,031 - 0,055 (0,0012 - 0,0022)
Limit	0,11 (0,0043)

GI

MA

EM

LC

EC

FE

CL

MT

AT

TF

PD

FA

RA

BR

ST

RS

BT

HA

EL

SE

IDX