

OWNER'S
MANUAL

Argonaut

MODEL

505

C O N T E N T S

SECTION	TITLE	PAGE
1	INTRODUCTION	1-1
	CONDENSED OPERATING INSTRUCTIONS	1-1
	GENERAL OPERATION	1-3
	TECHNICAL SPECIFICATIONS	1-5
2	OPERATION	
	POWER SUPPLY	2-1
	ANTENNA	2-1
	MICROPHONE	2-1
	KEY	2-2
	CW DRIVE	2-2
	SPEAKER/PHONES	2-2
	RF/AF	2-2
	MODE	2-3
	METER SWITCH/SENSITIVITY	2-3
	BANDSWITCH	2-3
	RESONATE	2-3
	OFF-SET	2-4
	PANEL LIGHTS	2-4
	WWV	2-4
	3	ALIGNMENT AND SERVICE
PILOT LIGHTS		3-1
DIAL CORD		3-1
DIAL CALIBRATION		3-1
DISASSEMBLY		3-2
TRANSMITTER		3-3
RECEIVER		3-5
TRANSMITTER MIXER BALANCE		3-5
SWR BRIDGE		3-6
S METER		3-6
WARRANTY		3-6
SERVICE		3-6
4	MODULES	
	OSCILLATOR	4-1
	RX, TX MIXER	4-3
	SWR BRIDGE	4-5
	RF POWER AMPLIFIER	4-6
	I.F. MODULE	4-7
	AUDIO AMPLIFIER	4-8
	SIDEBAND GENERATOR AND FILTER	4-9
	CONTROL BOARD	4-11

TEN-TEC, INC.
 Sevierville,
 Tennessee 37862
 (615) 453-7172

SECTION I

INTRODUCTION

The Argonaut opens a whole new world of excitement and fun in Amateur Radio. We think you will find QRP a welcome change. Five watts are only $2\frac{1}{2}$ S-units below 150 watts for the same conditions. When skip is favorable and QRM light, you will not be conscious of using low power.

The small size (1/5 cubic foot) makes it ideal for portable operation in a motel, camper, trailer, or mobile operation in your car, boat or plane. As a result of its low power requirement, a 12 volt lantern or automobile battery will provide many, many operating hours. An ac pack, available as an accessory, will provide 115/230 volt operation. You can choose ssb or cw on any ham band between 3.5 and 30 MHz.

On the following pages you will find a set of condensed operating instructions. These are sufficient to place the Argonaut in operation. We do, however, highly recommend a thorough reading of the detailed instructions and the theory of operation. Only by a complete understanding of all controls can the Argonaut be used to its maximum capabilities.

CONDENSED OPERATING INSTRUCTIONS

The following instructions will enable the operator to quickly place the Argonaut in operation. For a more comprehensive description of the controls and their functions, read the detailed operating instructions.

REAR APRON CONNECTIONS AND CONTROLS

- +12 VOLTS IN JACK - Use a 12 to 14 volt, dc power source capable of delivering one ampere, negative ground.
- ANTENNA JACK - Connect a 50 to 75 ohm, unbalanced resonant antenna such as a beam, dipole or vertical. Balanced antennas and those with higher impedances should be matched to the Argonaut with an antenna tuner, such as the TEN-TEC Model AC5-205.
- MIC JACK - If ssb operation is intended, use a high impedance dynamic crystal or ceramic microphone. Use a PL-68 plug -- tip to Push-To-Talk switch, band to microphone, and sleeve to common ground.

KEY JACK - If cw operation is intended, connect a straight key, bug or electronic keyer.

MIC GAIN and CW DRIVE Controls - Set as outlined in the following Tune-Up section below.

FRONT PANEL CONTROLS

A.) Tune-Up

- 1.) Select desired band with BAND switch.
- 2.) Tune dial to approximate frequency desired.
- 3.) Set METER switch to FORWARD position and SENSITIVITY control to about mid rotation.
- 4.) Advance MODE switch from OFF to LOCK position.
- 5.) Rotate CW DRIVE control on rear apron to about mid position.
- 6.) Set RESONATE control first to a position so that the pointer indicated the desired band and then reset it slightly for peak meter reading. (On some bands it is possible to obtain two or more meter peaks as the RESONATE control is rotated over its full range. The only correct setting is the one where the pointer closely indicates the operating band.) Use the SENSITIVITY control to maintain an adequate meter deflection.
- 7.) With SENSITIVITY control set to the dot position, re-adjust CW DRIVE control for full scale meter deflection. This procedure insures maximum output without overdrive.

B.) Operation - CW

- 1.) Reset MODE switch to CW position.
- 2.) To transmit, merely key the Argonaut for complete break-in operation.
- 3.) To receive, adjust AF and RF controls for desired audio level.
- 4.) For OFFSET tuning procedure, refer to the detailed operating instructions.

C.) Operation - SSB

- 1.) Reset MODE switch to SBN position.

- 2.) Set MIC GAIN control on rear apron so that with the push-to-talk switch closed, voice peaks cause the meter to deflect to about 3/4 of full scale with SENSITIVITY control set to the dot position.
- 3.) To receive, adjust AF and RF controls for desired audio level.

D.) Operation - General Notes

- 1.) When the METER switch is set to the S MTR position, incoming signal strength can be determined, provided the RF gain control is advanced to maximum.
- 2.) The S-meter will deflect to full scale in the transmit mode. This is normal.
- 3.) An alternate method to correctly set the RESONATE control is to put the transceiver in the receive mode, advance the AF and RF controls to produce hiss, noise or a signal in the output, and then peak the control for maximum audio.
- 4.) The RESONATE control should be re-peaked whenever the operating frequency is changed by approximately 50 KHz or more on the low frequency bands.
- 5.) When changing bands, or going to the opposite ends of the 80 meter band, the MIC GAIN or CW DRIVE control should be reset so as to maintain maximum output without overdrive. Refer to step 7 under the Tune-Up procedure above.
- 6.) Although improper antenna will not damage the Argonaut, we suggest careful tune-up for maximum performance.

GENERAL-OPERATION

The Argonaut is the first miniaturized transceiver incorporating a full array of operating features. It operates on SSB/CW over the five popular Amateur H.F. bands including all segments of the 10 meter band. The input to the final stage is nominally five watts.

QRPP

This is the designation given to communication with input power of 5 watts or less. There are thousands of Amateurs who have found QRPP to be an enjoyable hobby. Clubs have been formed and contests are frequently conducted.

Five watts and less can work anywhere in the world under favorable propagation and interference conditions. The following

general observations might be helpful:

1. Select the highest frequency band that is completely open.
2. Call loud stations. We assume two-way skip which would also enhance your signal. Remember that 5 watts is 2.5 S-units below 150 watts so if you call an S-9 signal yours will be S-6/7 if antennas are equal.
3. Choose a part of the spectrum that is not heavily populated. A QRPp signal, especially a clean readable Argonaut signal, sometimes gets through QRM but in general it is better to stay out of QRM.
4. Don't call CQ except during favorable band conditions. There is a tendency for others to call strong signals.
5. Call and sign a little longer than when running high power. On CW send a little more slowly. With phone, announce clearly.

QRPp is not push-button communication. Because it does take skill and technique it is an exciting and challenging facet of Amateur Radio.

MOBILE OPERATION

The Argonaut is ideally adapted to mobile operation in a car, boat, plane or any other vehicle. It operates from a 12 volt battery source (cigar lighter outlet) and is self-contained except for key, microphone and antenna.

When using with an alternator charged battery, start the vehicle's engine before turning on. This avoids a voltage surge caused by momentarily open voltage regulator contacts.

Normally, there will be negligible noise introduced through the DC power leads. If it should occur, it can be eliminated by inserting the low voltage winding of a filament transformer in the power lead. ✱

It is usually not necessary to reduce the CW Drive control when operating from a fully charged storage battery.

FIXED STATION

The Argonaut with conventional antennas will perform with distinction in any ham shack. With a linear, the power can be increased to anything desired--up to the legal limit.

For an emergency or stand-by station it will operate for long periods with a 12 volt lantern or storage battery.

For use with a conventionally powered station, the receiver can be used as a separate unit, thereby splitting a transceiver for DX work. It is also a reserve stand-by receiver. WWV reports are available to those who do not have this feature on their set.

PORTABLE

The diminutive size and light weight of the Argonaut makes it an ideal traveling companion.

A 12 volt lantern battery (or two six volt batteries in series) will last many hours. To conserve battery power, be sure to switch off the dial light when not needed. Using headphones or reducing audio volume will conserve power. SSB will require less power than CW. The battery will give optimum results down to 10 volts. Below this, the CW drive (on CW) should be reduced to stabilize the oscillator current supply.

Antennas are a matter of choice and convenience. A mobile whip antenna may be used with a suitable ground system (radials) or excellent earth ground. Matched, resonant dipoles are fine if there is a support for them. A random length "long wire" is also effective but must be matched with an antenna tuner (TEN-TEC AC5 or equivalent). In any event, the SWR should be 3:1 or better.

SPECIFICATIONS

RECEIVER

SENSITIVITY - Less than .5uv for 10 db signal-plus-noise-to-noise ratio.

SELECTIVITY - 2.4 kHz at 6 dB down. 1.7:1 shape factor at 6/50 dB.

INPUT - Low impedance unbalanced coaxial input.

OUTPUT IMPEDANCE - 8 ohm speaker or headphones. (High or low impedance headphones can be used.)

POWER OUTPUT - 1 Watt at 8 ohms with less than 2% distortion.

SPURIOUS RESPONSE - More than 50 dB down.

AUTOMATIC GAIN CONTROL - (Max) For 100 dB change in input signal level, output changes 10 dB.

OFF-SET TUNING - With pull-out defeat switch.

TRANSMITTER

DC POWER INPUT - 5 Watts PEP; 5 watts CW

RF POWER OUTPUT - 2 Watts 80 through 15 meters, 1.8 watts on 10 meters. (50 ohm non-reactive load)

OUTPUT IMPEDANCE - 50 to 75 ohms

TRANSMIT-RECEIVE OPERATION - SSB: PTT. CW: Complete break-in

CW SIDE-TONE - Internally switched. Operates only in CW mode

MICROPHONE INPUT - High impedance. Crystal, ceramic or dynamic.

CARRIER SUPPRESSION - 40 dB from single tone output.

SIDEBAND SUPPRESSION - 30 dB Down from a single tone output at 1000 Hz reference.

GENERAL

FREQUENCY COVERAGE - 3.5 to 4.0, 7.0 to 7.5, 14.0 to 14.5, 21.0 to 21.5, 28.0 to 30.0 MHz.

FREQUENCY STABILITY - Less than 100 Hz after 30 minutes warm-up.

MODES OF OPERATION - Normal sideband, Reverse sideband, CW.

DIAL CALIBRATION - \pm 5 kHz on 80 through 15 meters, \pm 10 kHz on 10 meters.

POWER REQUIREMENTS - 12 VDC regulated to 10% with 1 ampere load.

CABINET DIMENSIONS - H.W.D. 4½" x 13" x 7½".

MATERIAL - Case, aluminum. Side panels, Cylolac.

NET WEIGHT - 6 pounds

SHIPPING WEIGHT - 8 pounds

TUNING RATE - Approximately 25 kHz per knob revolution, 80 meters through 15 meters. 100 kHz on 10 meters.

FRONT PANEL CONTROLS - Resonate. Off-set (pull-off). Band Selector. Tuning Knob. RF Gain. AF Gain. Mode Switch. Meter Switch. SWR Sensitivity.

REAR APRON CONTROLS - Antenna. Dial light switch. Microphone jack. Microphone gain. Headphone/speaker jack. CW drive. Auxilliary 12 V output jack. Key jack. Power in jack.

INTERNAL CONTROLS - "S" -meter adjust. Off-set tuning adjust. Side-tone volume.

SEMICONDUCTOR DEVICES - 33 Transistors, 3 Mosfet, 2 I.C. and 12 Diodes.

SECTION 2

DETAILED OPERATING INSTRUCTIONS

POWER SUPPLY

The Argonaut requires a supply of 12 volts capable of approximately 700 milliamperes peaks. The unit will operate satisfactorily, at reduced power and sensitivity down to +10 volts. It may be operated with any mobile installation having a 12 volt negative ground electrical system. When operating mobile it may be necessary to install a small choke in series with the +12 volt lead to eliminate alternator whine or generator noise. The secondary of a low voltage filament transformer or choke of similar current rating will work satisfactorily. For portable operation, the Argonaut may be powered by a 12 volt lantern battery or small storage battery.

ANTENNA

Any matched antenna presenting 50-75 ohms will work satisfactorily. Random length antenna or open wire fed systems will require a matching system similar to the TEN-TEC Model AC5. Any of the popular mobile antennas will operate without any special matching. If it is not mounted on a car, a good ground system or counterpoise should be provided. The Argonaut output is designed for an unbalanced feed system. The coax shield is connected to the shell of a phono plug and the center conductor is connected to the pin of the phono plug.

MICROPHONE

The input has been designed for a high impedance ceramic, crystal or dynamic microphone. The cable should be terminated in a type PL68 plug. The shield and/or ground lead is connected to the barrel. The push-to-talk switch is connected to the tip and the microphone to the sleeve.

The push-to-talk switch operates with respect to ground. The microphone gain control is located on the rear panel. The gain should be advanced, under normal operation, until the forward SWR reading reaches approximately 3/4 scale on voice peaks. The transmitter gain varies from band to band. This may require changing the microphone gain for proper operation.

KEY

The key actuates a series of circuits on the control board that supply voltage to the various transmit and receive stages. When the key is closed, bias is removed from the receive stages and applied to the transmit stages. The antenna is changed from receive to transmit with a reed relay. There is a small time constant in the audio muting circuit to eliminate any clicks while keying. It is not long enough to interfere with the complete break-in operation of the Argonaut. The CW side-tone operates only when the mode switch is in the CW position.

The side-tone volume is independent of the front panel volume control. The side-tone volume may be set to the desired level with the printed circuit thumb potentiometer located on the power amplifier board. (See Fig.1) This board is located directly behind the function switch and is accessible by removing the bottom cover plate.

CW DRIVE

This control is mounted directly above the phone jack. It controls the gain of the balanced modulator and is used to set the proper drive to the final amplifier. Over-drive on any band will not cause damage to the Argonaut. It will, however, result in an increased current drain for a given output. On 80, 40 and 20 meters it may be necessary to reduce the drive to avoid excessive current drain. If an AC pack is used, excessive current may exceed the regulated voltage limits and cause chirpy CW signals and distorted SSB.

SPEAKER/PHONES

A jack is provided for an external speaker or headphones. When in use, the jack will automatically disconnect the internal speaker. The amplifier output was designed for an 8 ohm load, but will perform satisfactorily with high impedance phones or speakers with 4 to 16 ohm impedance.

FRONT PANELRF/AF

The RF gain controls the bias to the receiver RF amplifier. There is approximately 20 to 25 dB gain reduction from maximum to minimum. This is used primarily to reduce the susceptibility to overload in the presence of extremely strong signals. The AGC will be dependent on the RF gain setting. The AF control controls the input to the power amplifier stage.

MODE

SBN is the sideband normally in use on all bands. It will provide upper side band on 20, 15 and 10 meters and lower sideband on 40 and 80 meters. The proper sideband is automatically selected by using either the sum or difference frequency in the mixer. The opposite or reverse sideband can be selected on the MODE switch (SBR) when needed.

The CW position connects the side-tone and disables the balanced modulator. The receiver is operated on the normal sideband. The transmitted signal is automatically offset 700 Hz from the received signal. This will compensate for the BFO beat note and allows the transmitter to be on the frequency of the received signal.

The lock position is used for tune-up purposes. It places the transmitter on the CW frequency and energizes the control board and antenna relay. Turn meter switch to FORWARD and tune RESONATE to maximum meter reading.

METER SW AND SENSITIVITY

The meter may be used as an "S" meter or with the built-in SWR bridge. It has provision for reading both forward and reflected power. The switch is placed in the forward position and the transmitter is turned on. Set the meter to full scale with the sensitivity control. Switch to Reflected to read the standing wave ratio (SWR).

BANDSWITCH

The bandswitch selects the Amateur bands of 80, 40, 20, 15 and 10 meters. It switches both the main VFO frequency and the transmitter/receiver tuned circuits.

RESONATE

The RESONATE control operates a mechanical assembly that permeability tunes the receiver and transmitter circuits. This may be peaked on a received signal or, by using the SWR meter, peaked for maximum power output. This is all the tuning required when changing bands. The broadband final amplifier does not require any adjustments.

CAUTION:

Be sure the RESONATE control is tuned to the proper frequency. There are other frequencies that can be peaked by this control.

If there is any doubt, tune for maximum on received signals in the band selected.

OFF-SET TUNING

The OFF-SET control tunes the receiver independently of the transmitter. A push-pull switch is attached and the off-set is disabled by pulling the knob out. It is more convenient to leave the off-set control in operation and set to zero. It is then instantly available when needed. The circuitry is stable and should not change frequency. The zero is checked by turning the off-set on and off without changing the frequency of the received signal.

PANEL LIGHTS

A slide switch is located on the rear of the unit to turn the panel lights on and off. This allows a minimum drain when the unit is operated from a battery supply.

WWV

The broadcasts of WWV and WWVH may be received on 15 MHz by the following tuning procedure.

1. Set the band switch to 15 METERS.
2. Turn the slide rule dial and the frequency readout dial to zero.
3. Tune the RESONATE control to an area between 40 and 80. By tuning RESONATE and the frequency readout dial, WWV will be heard if the band is open.
4. Tune the frequency read out dial until the receiver zero beats with WWV.
5. Turn the aluminum dial to zero. It may be necessary to hold the black tuning knob when turning the read out dial.
6. This calibrates the 15 meter band only.

SECTION 3

PILOT LIGHT REPLACEMENT

There are three pilot lights in the Argonaut. One is located behind the meter and two between the front panel and sub-panel. The meter light is a number 49 bayonet bulb. To replace, remove the top. The remaining dial lights require removal of the front panel. Refer to alignment section for instructions on front panel removal. These bulbs are miniature 6 volt 50 ma. units. They are available through TEN-TEC for \$.50 each.

DIAL CORD REPLACEMENT

It is recommended that .030 diameter glass reinforced dial cord be used to eliminate any stretch. Tie the dial cord to the small spring. The spring is connected to the right hole in the molded pointer. Run the cord around the two pulleys on the right, clockwise around the shaft three turns, above the next pulley and around the remaining two pulleys. Thread the cord through the left hole in the pointer. Be sure to thread the cord from the outside toward the subpanel. Pull the cord tightly enough to stretch the spring slightly and tie. Be sure the knot is toward the front edge of the pointer. This will pull the pointer down on the sub-panel. Tune in a band edge and slip the string so the pointer coincides with zero on the dial.

DIAL CALIBRATION

- 1.) The dial string pointer is meant only as a turns indicator for the linearly calibrated 0-100 kHz permeability tuned oscillator dial. Although the string pointer is set accurately at the time the transceiver leaves the factory, it may, in time, vary slightly from the zero setting due to string slippage and stretch.
- 2.) The PTO oscillator dial skirt is attached to the control shaft by means of a friction clutch. By holding the knob firmly, the skirt can be rotated to calibrate it to zero setting when using a crystal calibrator, or WWV as described below. At the time of shipment, the skirt is accurately set. However, if in turning the black tuning knob the fingers touch the skirt with any force, the skirt may deviate from its true setting. Caution should be used when tuning the transceiver so that only the black knob is grasped.

- 3.) To re-calibrate the dial with the aid of a crystal calibrator, loosely couple its output to the antenna so that a signal is picked up at any convenient 100 kHz setting. Zero beat the signal with the main tuning knob. Then hold the knob and rotate the skirt to the zero setting. The transceiver will then be calibrated on all bands within the published accuracy.
- 4.) If no crystal calibrator is handy, WWV at 15 MHz can be received and used for calibration as follows: Set band switch to the 15 meter position. Rotate RESONATE control, not to its normal 15 meter position, but counterclockwise to the 80 meter segment until the noise level increases. Turn main tuning so that lower band edge is tuned in, (zero on 0-5 scale). Around this position, WWV will be heard if within range. Zero signal in with main tuning knob and set skirt of dial as above.
- 5.) The skirt markings are in kHz for all bands except the 10 meter band. On this band, the tuning ratio is increased four times, so that the true frequency increment is four times that indicated by the skirt readout. Thus, one rotation of the skirt dial represents 400 kHz on the 10 meter band.
- 6.) If it is necessary to realign any of the bands for position or linearity, refer to the section covering the oscillator.

ARGONAUT ALIGNMENT

1.) REMOVAL OF TOP

Remove the two screws at the extreme edges of the rear of the top. Slide the top back and out of the grooves in the side panels. It is recommended that the speaker wires be disconnected from the speaker to eliminate any possibility of damage during service.

2.) REMOVAL OF BOTTOM PLATE

Remove the four screws in the bottom plate. Slide the bottom back and out of the grooves in the side panel.

This should be sufficient for any alignment necessary on the circuitry.

Dial cord, pilot light and switch linkage are behind the front panel.

FRONT PANEL REMOVAL

Remove the knobs and dial plate. The dial plate is a friction fit to the VFO shaft. It can be removed by pulling away from the front panel. Remove the four screws in the bottom of the front panel. Loosen one side panel "Z" bracket. The "Z" brackets are located at

the top of each side panel and are secured to the subpanel. Carefully lift the front of the side panel and slip out the front panel.

ALIGNMENT OF TRANSMITTER AND RECEIVER CIRCUITRY

Connect the Following Equipment:

- 1.) Dummy load to the antenna jack.
- 2.) Oscilloscope to test point 1 shown in figure 1.
- 3.) RF output meter or oscilloscope across the dummy load. (The internal SWR meter may be used but an RF voltmeter will result in greater accuracy.)

Set the Bandswitch to 80 and the Frequency to 4.0 MHz.

- 1.) Turn function switch to "Lock".
- 2.) Set CW DRIVE to approximately 3/4 rotation.
- 3.) Set RESONATE control to full CCW.
- 4.) Rotate RESONATE control until there is an indication on the oscilloscope. The waveform will contain harmonics at this point in the circuit.
- 5.) Peak the TX BUF and TX DRIVER coils, located in the RF front end assembly for maximum output. (Fig. 2).
- 6.) Set the frequency for 3.5 MHz.
- 7.) Rotate the RESONATE control CCW until a peak is observed at the test point.
- 8.) Tune the buffer and driver trimmers for maximum output. Trimmer location is shown in figure 1.
- 9.) Repeat the procedure until there is no more increase in output. There will be a variation of gain across the 80 meter band. This variation will be approximately 10dB from 3.5 MHz to 4.0 MHz. There is sufficient reserve gain in the generator and mixer to compensate this loss.

Turn the Band Switch to 10 meters and set the Frequency to 30 MHz.

- 1.) Rotate the function switch to lock.
- 2.) Set RESONATE CONTROL just short of full CW rotation.

- 3.) Adjust the mixer trimmer, located on the TRANS/RECV mixer board, the buffer and driver trimmer for maximum output. (Fig. 1 & 2).

Turn the bandswitch to 15 meters.

- 1.) Rotate the RESONATE control in the area of the 15 meter indication on the front panel until there is a peak at the test point.
- 2.) Tune both buffer & driver trimmers for maximum output.

Proceed with 40 and 20 Meters.

NOTE: There will be indications at the test point other than the correct response. This is due to the two oscillator frequencies and their mixer products. Care should be exercised to make sure the correct response is chosen. The correct response should coincide at or near the front panel markings on the RESONATE control. The 40, 20, and 15 meter indication will in general be quite close together.

FILTER ALIGNMENT

(Set Frequency to the Top of Each Band)

- 1.) Connect a two-tone test oscillator of approximately 150 mv output to the microphone input. Set function switch to SBN and ground the key jack. Set the bandswitch to 10 and rotate the RESONATE control for maximum output. Set the microphone gain to show slight flat-topping of the two-tone signal. Adjust coil L6 for maximum output. This will be very broad. The output voltage should be approximately 9.0 vrms when measured with a peak responding meter. This filter is set to roll off above 30 MHz. (Fig. 1)
- 2.) 15 METERS
Peak RESONATE control for maximum output. Check the output voltage and waveform. The meter should read 9.0 vrms. One filter (L6, C36, C37) is used for both 10 and 15 meters. It is only necessary to adjust this filter at the high frequency end of the 10 meter band.
- 3.) 20 METERS
Peak RESONATE control for maximum output. It will be necessary to readjust the MIC GAIN to eliminate overdrive. Adjust L7 for maximum output. L7, L8, and L9 are located through the moveable plate behind the RESONATE control. (Fig. 2)

- 4.) Proceed with 40 and 80 meters adjusting L8 and L9.

RECEIVER ALIGNMENT

80 METERS

- 1.) Set the frequency to 4.0 MHz and adjust transmitter, as before, for maximum output.
- 2.) Disconnect the dummy load and connect a signal generator to the antenna jack.
- 3.) Adjust the generator frequency and output for a convenient reading on the S meter. Keep the S meter reading as low as possible for greatest sensitivity.
- 4.) Peak receiver input, RX RF, and receiver output, RX MIX for maximum. (Fig. 2)
- 5.) Tune frequency to 3.5 MHz. Connect dummy load and RESONATE on transmit as before.
- 6.) Connect generator and tune the trimmer capacitors for maximum output. (Fig. 1)
- 7.) Repeat until there is no further increase in sensitivity.

40 METERS

- 1.) Connect dummy load and adjust the transmitter for maximum output.
- 2.) Connect the signal generator to the antenna jack and adjust the frequency and output for a convenient reading on the "S" meter.
- 3.) Peak the receiver input and output trimmers for maximum output.

Align the remaining bands as outlined for 40 meters. The 80 meter alignment sets the coils (L1 and L2) to the proper inductance. Be sure to adjust the transmitter output for maximum with the RESONATE control before peaking the receiver trimmers. This will insure that maximum sensitivity in the receiver and maximum output of the transmitter will coincide.

TRANSMITTER MIXER BALANCE CONTROL

This control is a printed circuit potentiometer located on the TRANS/RCVR mixer board. Its function is to balance the odd harmonics of the local oscillator. (Fig. 2)

1. Set the unit for operation, as a transmitter, on the 20 meter band. Adjust the RESONATE and CW DRIVE control for a convenient reading on the oscilloscope. Reduce the CW DRIVE control to minimum and increase scope sensitivity for a convenient reading. The RESONATE control is now set to 14 MHz. Rotate the RESONATE control carefully clockwise to obtain a reading on the scope at about 15 MHz. This represents the third harmonic of the local oscillator. Turn the potentiometer for a minimum signal. A definite null should be obtained, but not a complete zero.

SWR BRIDGE

Connect a suitable 50 ohm load to the antenna. Adjust the transmitter for full output on the 10 meter band. Set the SWR switch to FORWARD and SENSITIVITY control to maximum CW rotation. Adjust CW DRIVE control for a full scale reading. Switch to REVERSE and adjust the trimmer located on the SWR board for a minimum reading.

S-METER

The S-Meter is located in a bridge type circuit. With the receiver in operation but without any signal or noise adjust the S-Meter potentiometer (Located on the control board) for zero.

WARRANTY

The ARGONAUT is guaranteed to be free from defects in workmanship and material for a period of one year from date of purchase. This does not cover (1) damage due to mishandling, (2) voltages in excess of rating, (3) reverse polarity (positive ground) or (4) changes in circuitry.

SERVICE

In the event of failure during warranty, there is no penalty or voiding of the warranty if the user attempts to make repairs. As most circuit boards plug in, we suggest you refer to the owner's manual and return the defective board to us for replacement. If the failure is in the tuning unit or the PTO, the entire unit must be returned for factory service. If, however, you prefer to return the complete set, pack it carefully so that the tuning knob is protected from shock and send it postpaid by Parcel Post or UPS to TEN-TEC, INC., Sevierville, Tn. 37862. It will be repaired and returned, postpaid.

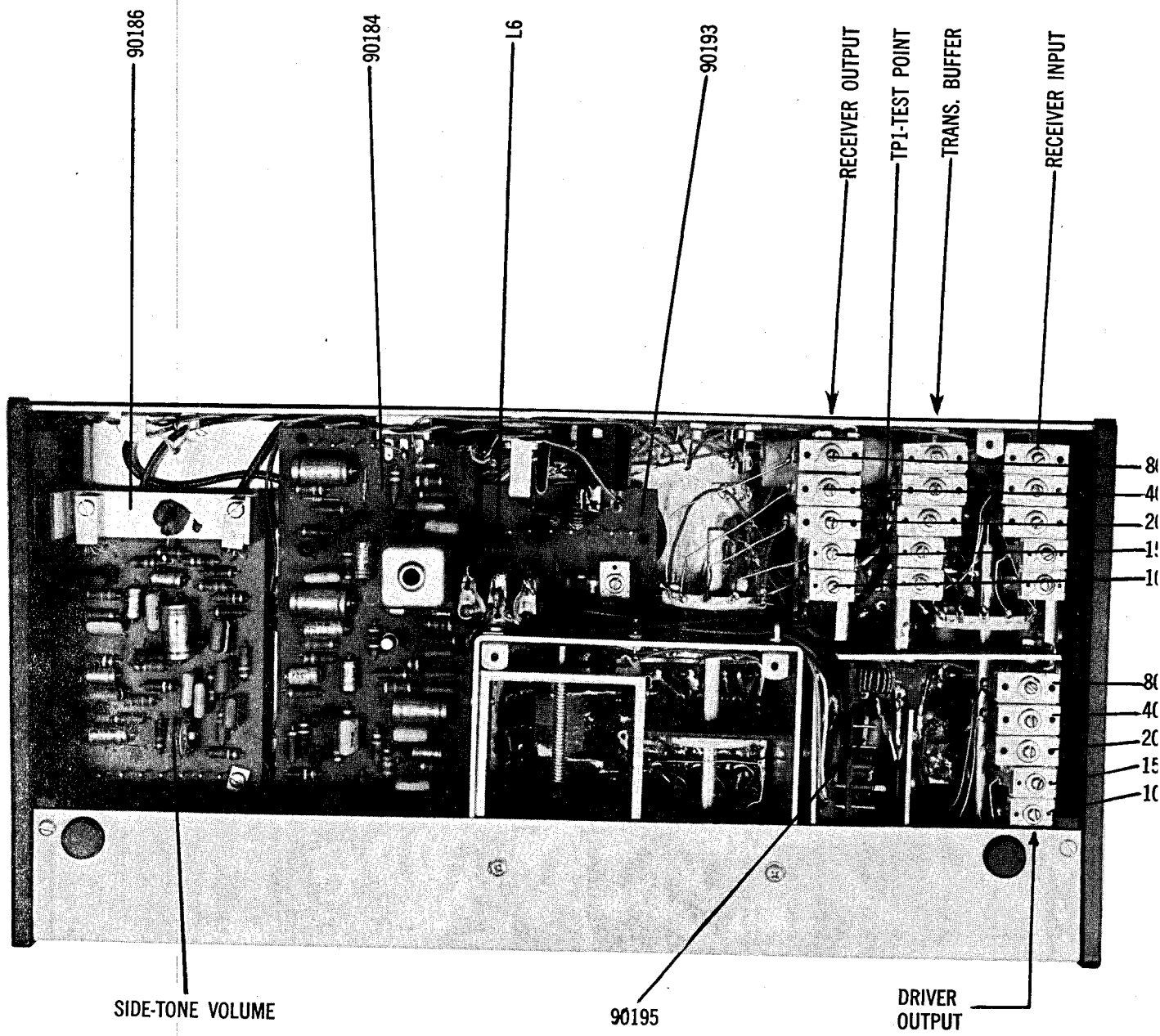

FIGURE 1

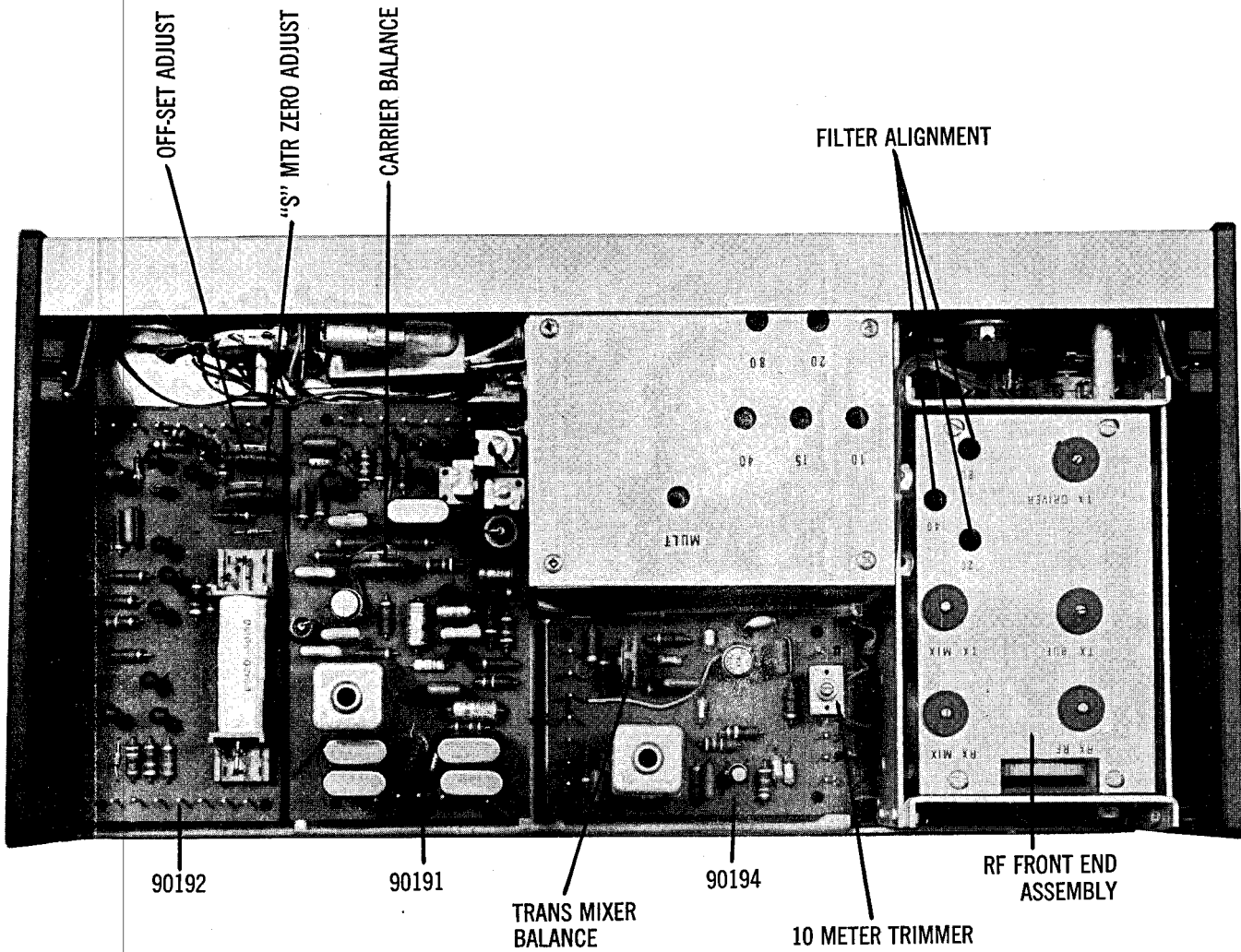
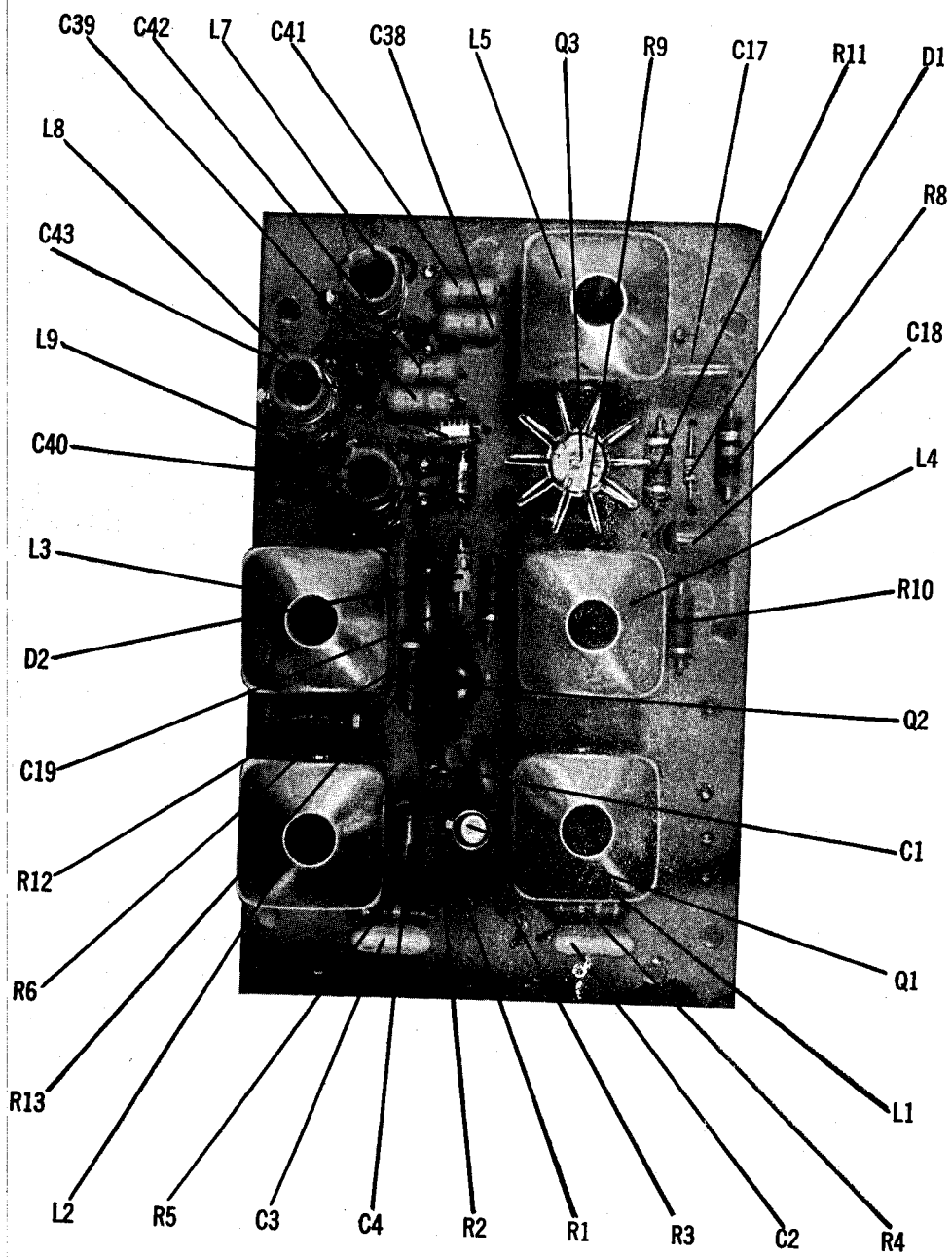

FIGURE 2



90197 R.F. FRONT END BOARD

SECTION 4

OSCILLATOR

The variable oscillator produces the proper injection frequencies for a transceiver, transmitter or receiver using a 9 MHz I.F. system. Q2 is the basic oscillator followed by Q3 as a buffer. Transistor Q4 is used as a multiplier. Offset tuning has been incorporated using the junction capacity of Q1 as the capacitor.

Tuning is accomplished by varying the inductance of L11. The proper frequencies are obtained by changing the basic oscillator frequency and by using the correct multiple. Table I shows the basic frequency, multiple and injection frequency.

TABLE I	BAND	BASIC FREQUENCY MHz	MULTIPLE	INJECTION FREQUENCY MHz
	80	6.250-6.500	X2	12.5-13.0
	40	5.333-5.500	X3	16.0-16.5
	20	5.000-5.500	X1	5.0- 5.5
	15	6.000-6.250	X2	12.0-12.5
	10	6.333-7.000	X3	19.0-21.0

The basic frequencies for all bands are close together. Therefore, the linearity of tuning is maintained on all bands. The frequency range and band edge can be adjusted with coils L1 through L10. For instance, on 80 meters, to increase the tuning range, increase the inductance of L2 (move bottom slug CCW) and decrease the inductance of L1 (move top slug CCW). To decrease the range the procedure is reversed (move both slugs CW). The same procedure holds for 40 through 10 meters. All coils L1 through L10 are located beneath the openings in the top cover.

MULTIPLIER TUNING

Set the oscillator to 10 meters and the frequency to 6333 kHz. Peak both the bottom and top slugs in T1 for 19 MHz. Set the oscillator to 7000 kHz and check the output. It should be close to that obtained at 19 MHz. If necessary, repeat the top slug slightly. This is an over coupled double-tuned transformer and will require a little care in obtaining the proper passband. When properly tuned it should peak toward each frequency extreme with a shallow dip in the center. The other bands are tuned with the trimmer capacitors located on the circuit board. It is important that 10 meters is properly adjusted before proceeding with other bands. Switch the oscillator to 15 meters and the frequency to 6.000 MHz. Peak both C14 & C15 for 12.0 MHz and check the output. The multiplier passband is set to pass both 80 and 15 meters. This will be a frequency range of 12.0 to 13.0 MHz. The two peaks of the over-coupled transformer will fall at 12.0 and 13.0 MHz. The output at the high frequency of 15 meters should coincide with the output at the low frequency end of 80 meters and will be about 3 dB

below either extreme. Switch to 80 meters and check the output at 13.0 MHz. If necessary, repeak C15 for maximum. On 40 meters, the multiplier only has to pass 16.0 to 16.5 MHz. It is only necessary to set the frequency to 5.367 MHz and peak both C13 and C16 for maximum output at 16.1 MHz. This should provide the proper injection across the 40 meter band.

The OFFSET tuning may be connected to a +9V regulated supply if it is not to be used. The offset range will vary from band to band due to the multiplier. For a voltage swing from +3V to +6V it will vary approximately ± 2 kHz on 20 meters, ± 4 kHz on 80 and 15 meters and approximately ± 6 kHz on 40 and 10 meters.

SPECIFICATIONS

FREQUENCY COVERAGE:

80	12.5 to 13.0 MHz
40	16.0 to 16.5 MHz
20	5.0 to 5.5 MHz
15	12.0 to 12.5 MHz
10	19.0 to 21.0 MHz

LINEARITY:

80, 40, 20, 15	± 5 kHz
10	± 10 kHz

STABILITY: Less than 100 Hz drift

OUTPUT: 1.0 to 2.0 volts, low impedance

POWER: +9V regulated @ 24 mA

SIZE: HWD 4" x 4" x 3½"

WEIGHT: 1 #

VOLTAGE READINGS

	COLL	BASE	EMITTER
Q1	+9.0	0	0
Q2	+8.0	+2.6	+3.2
Q3	+8.2	+3.0	+2.4
Q4	+8.0	+2.0	+3.2

The above measurements were taken with a VTVM. Offset connected to +9V. Transistor pin arrangement viewed from the bottom of the circuit board.

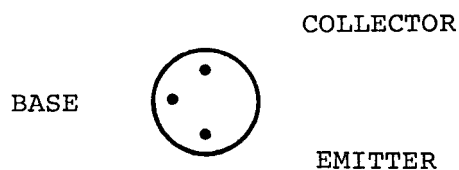

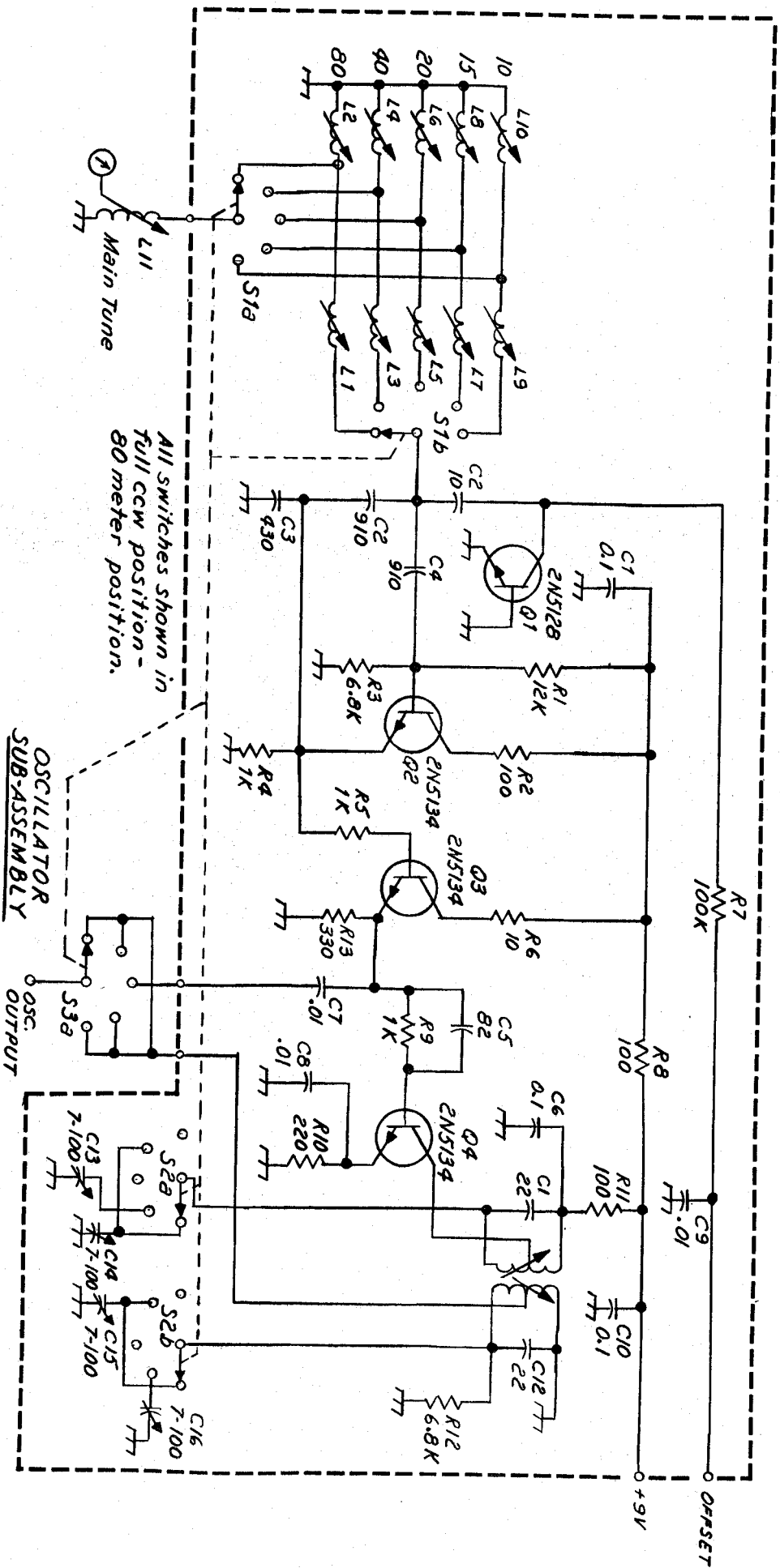

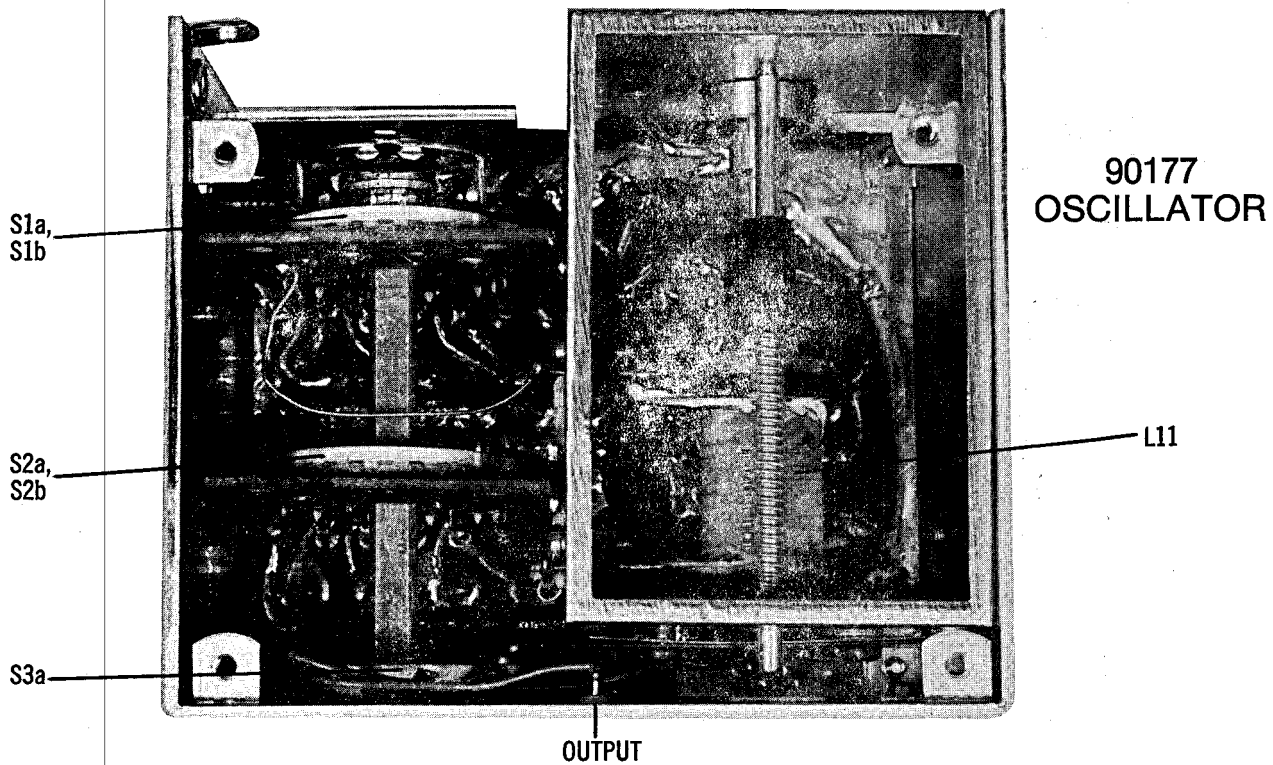
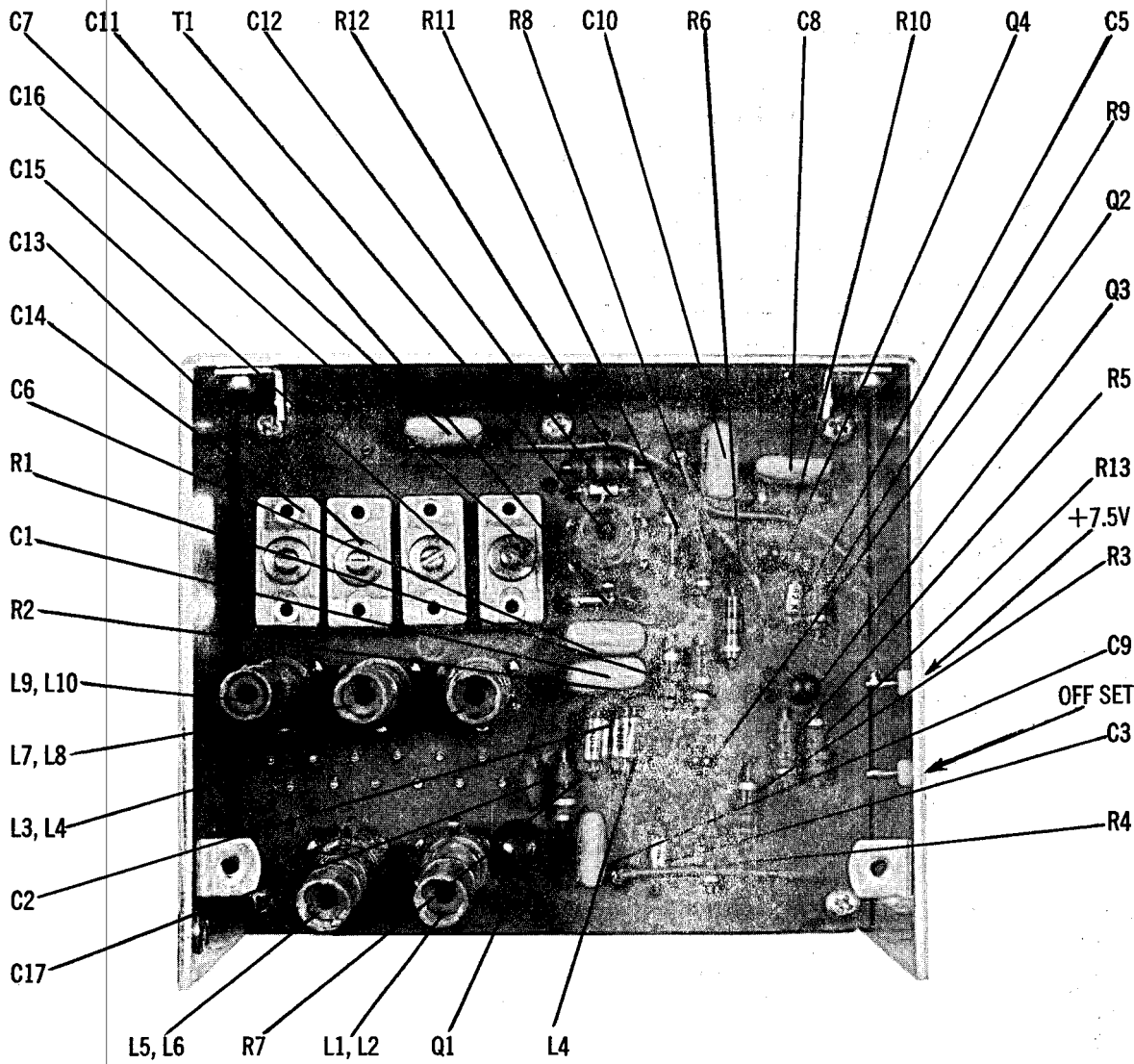

RX TX MIXER

The receiver mixer is built around a protected gate field effect transistor. The input is untuned and brought out to a terminal through a 22 pf capacitor. It is intended to be used with a high impedance drive such as the output of an rf amplifier. The output is a single tuned circuit lightly coupled through a 22 pf capacitor to the output pin. This provides a good match to a crystal filter such as used in the TEN-TEC sideband generator board, or other filter with a 470 ohm input impedance.

The transmitter mixer consists of a differential amplifier integrated circuit connected as a balanced mixer. The output of the balanced mixer is brought to three terminals and should be connected to a balanced tuned circuit such as used in the TEN-TEC Argonaut. Balance potentiometer R9 should be adjusted for minimum VFO feed through on odd harmonics.

The two mixers are interconnected on the circuit board so there is only one terminal for the 9 MHz IF filter of SSB signal and one terminal for the VFO injection. The receiver mixer positive voltage is brought out to the "R" terminal. It should be switched to ground during transmit to eliminate any tendency for interaction between mixers. The transmitter mixer bias is brought out to the "T" terminal. It should be switched to ground during receiving. Capacitor C14 is used to resonate the coil in the Argonaut on 10 meters.

CONNECTIONS

GND: GND

RX IN: High impedance source such as rf amplifier output coil

TX

TX Connect to a balanced coil

TX

R: +10 to 12 volts in receive mode

9MHz: To crystal filter. Load approximately 470 ohms for receive.
For transmit, SSB signal should be approximately .5 volts.

VFO: Injection voltage should be 1.0 to 2.0 volts

"T": + 8.0 to 12.0 volts in transmit mode.

+12V: Power In

VOLTAGE READINGS

Q1		CA3053	
Source	+2.6	1 +8.2	5 +8.2
Drain	+9.5	2 +3.0	6 +12
Gate 1	+2.6	3 - 0	7 +12
Gate 2	+1	4 +2.2	8 +12

The above readings were taken with "R" and "T" connected to +12 volts and the three TX terminals connected together. All measurements with a VTVM.

Pin arrangements viewed from the bottom of the circuit board.

SOURCE



GATE 1

DRAIN



GATE 2

CA3053

SIZE : 2" x 3 1/4" x 2 1/4"

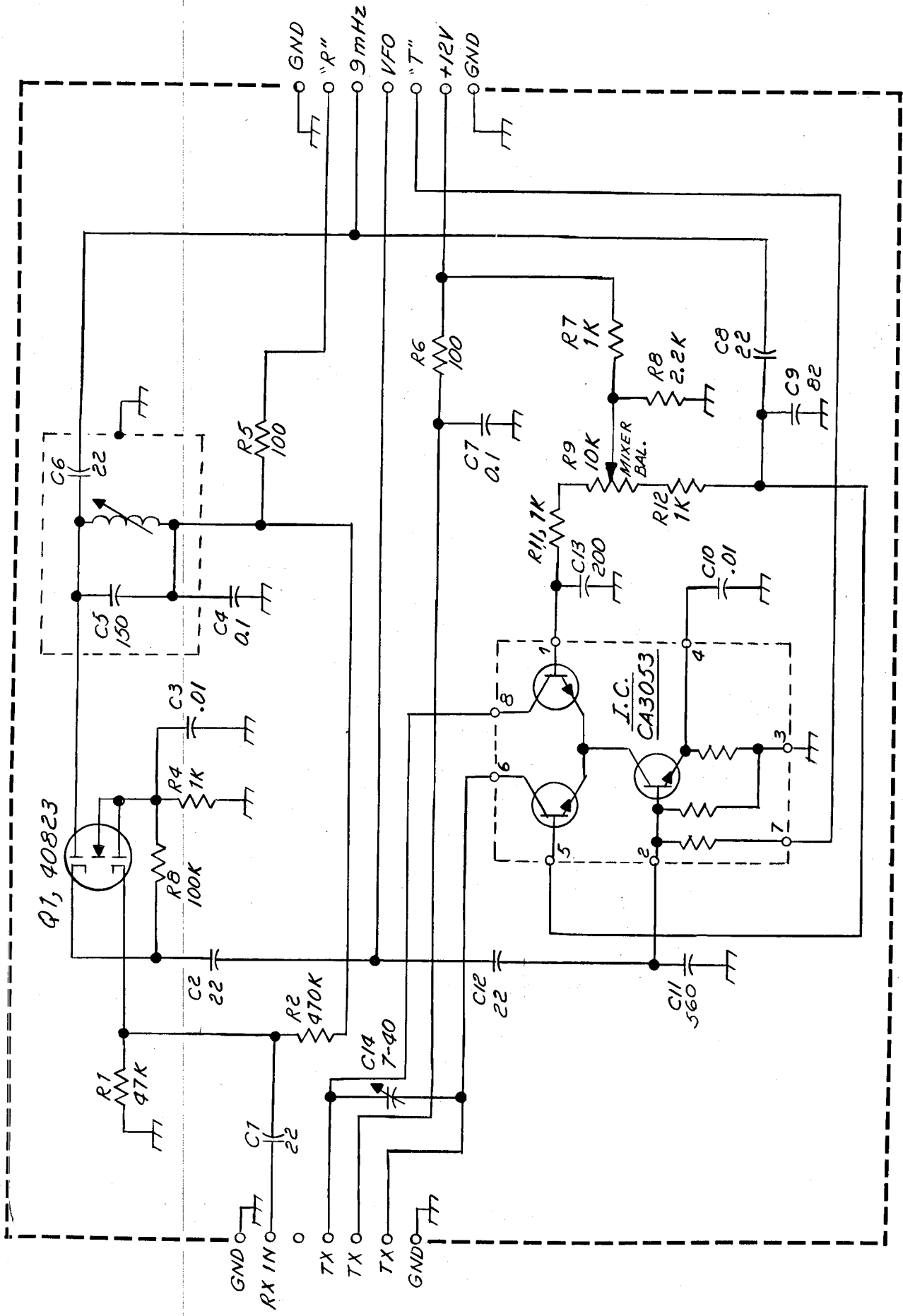

Pins viewed from top of board

90194 RX & TX MIXER

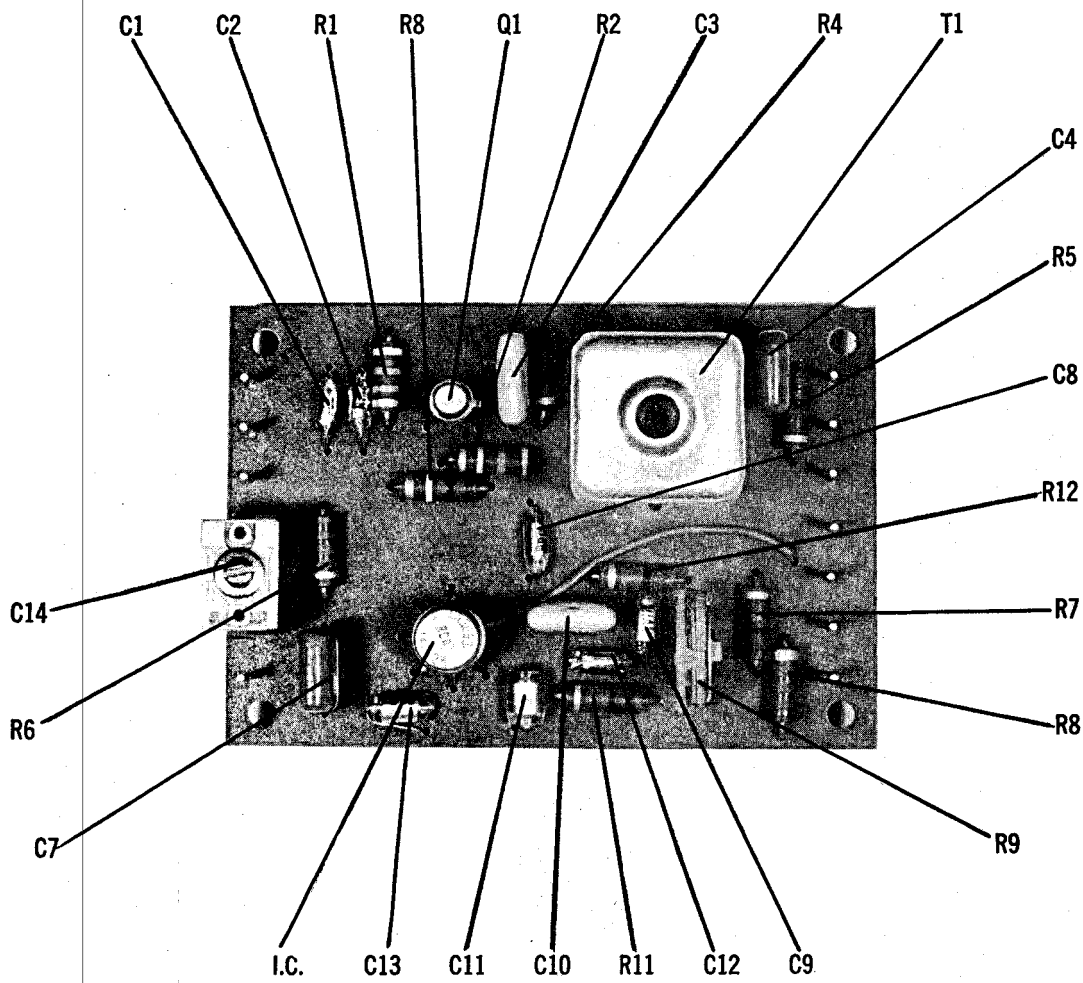

90194 RX & TX MIXER

SWR BRIDGE

Current transformer T1 along with the capacitive divider C1 and C2 sample the power in the transmission line. Diodes D1 and D2 rectify the forward and reverse power and feed a DC voltage to the appropriate terminals. To adjust the balance, null the reflected reading with C1 at the highest frequency used. With a 500 ua meter as an indicator it should be possible to read a match with powers as low as 1 watt. The reading will be insensitive to frequency.

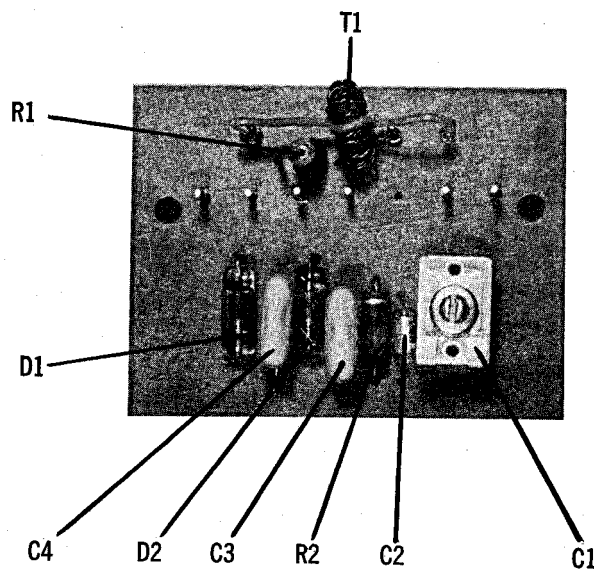

90193 SWR BRIDGE

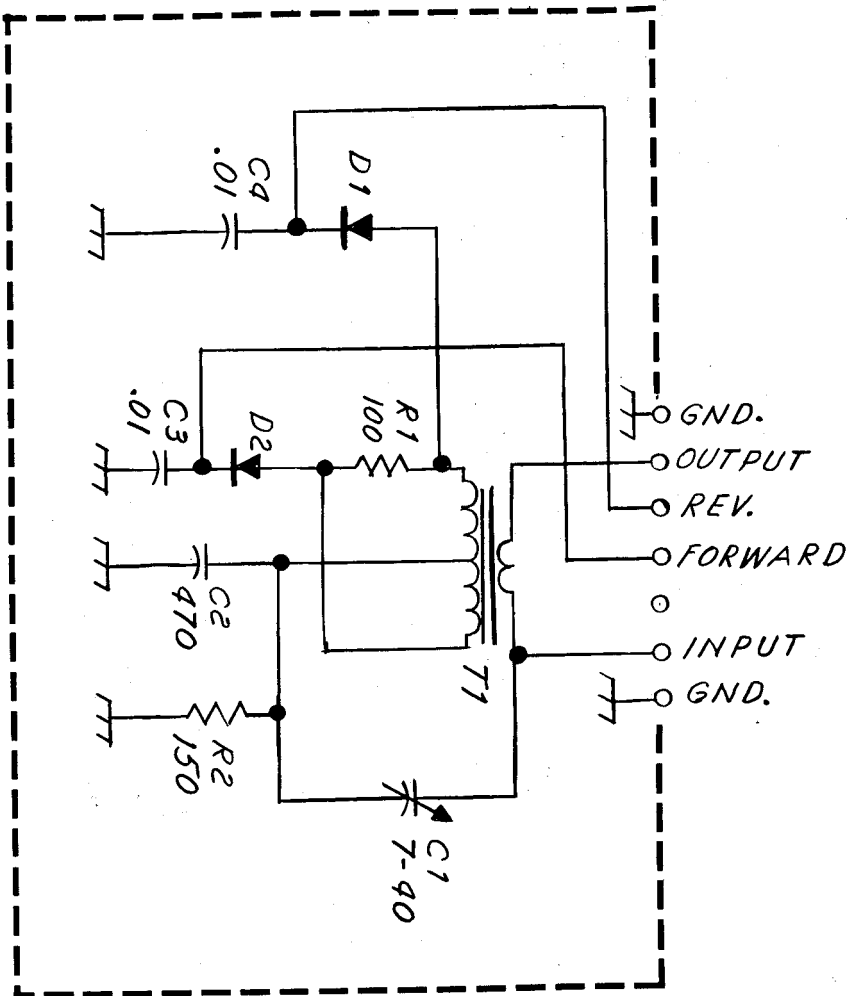

90193 SWR BRIDGE

*Pins viewed from top of board.
 D1 & D2 1N542 matched diodes.
 T1 toroid transformer.*

RF POWER AMPLIFIER

The RF power amplifier is a broadband design. It operates over a frequency range from 1.5 MHz to 30 MHz. Transformers T1 and T2 form a broadband impedance matching network to transform the low impedance at the base of Q1 and Q2 to 50 ohms. The supply voltage may be between 12 and 14 volts. Transformers T5 and T6 transform the output impedance to 50 ohms. The "Bias" pin is either connected to the main supply or to the "T" terminal on the control board module. It is recommended that the output be followed by some form of lowpass filter to reduce harmonics. The harmonics without any form of selectivity are between 30 and 35 dB down from the main signal. Although the output was designed for a 50 ohm load it will work satisfactorily with loads between 30 and 75 ohms. It is quite rugged and will not be damaged by a momentary open or short circuit at the output.

SPECIFICATIONS

INPUT IMPEDANCE : 50 ohms SIZE : HWD 1½" x 3" x 1½"
 OUTPUT IMPEDANCE : 50 ohms
 SUPPLY VOLTAGE : +12 to +14 volts
 INPUT POWER : Linear, +12 volt supply, 5W, PEP
 EFFICIENCY : 30 to 40%
 INPUT VOLTAGE (RMS) FOR 5W, PEP : 1.5 to 11 MHz .4 V

From 11 MHz required input voltage will increase to a value of 2.5 VRMS at 30 MHz

VOLTAGE READINGS

	COLLECTOR	BASE	EMITTER
Q1	+12V	+.55	.003
Q2	+12V	+.55	.003

The above measurements were taken with a VTVM under no signal conditions.

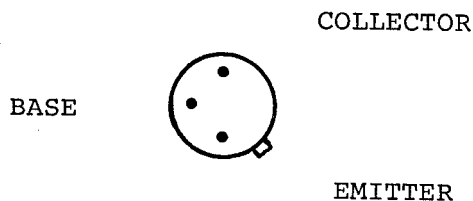

Transistor pin arrangement viewed from the bottom of the transistor.

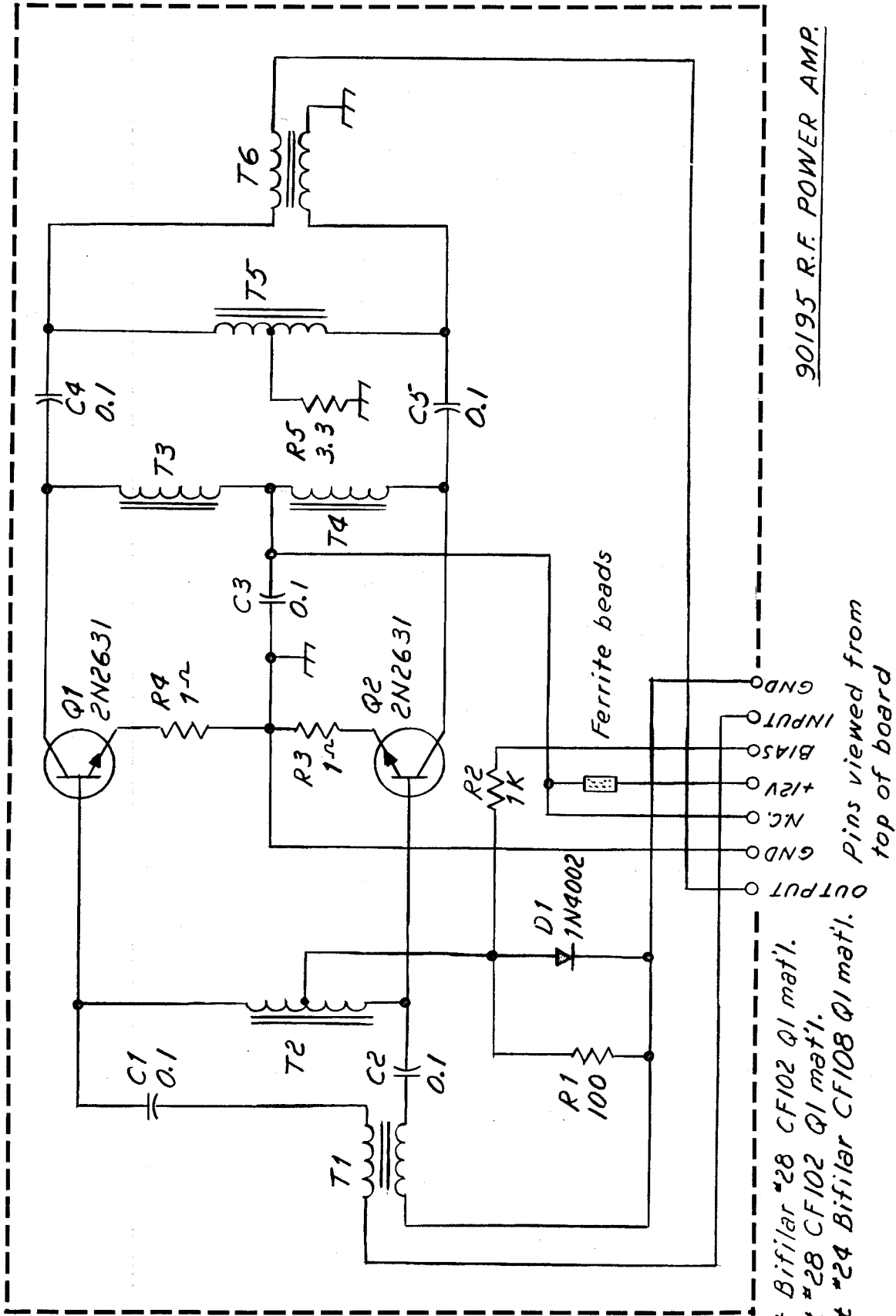

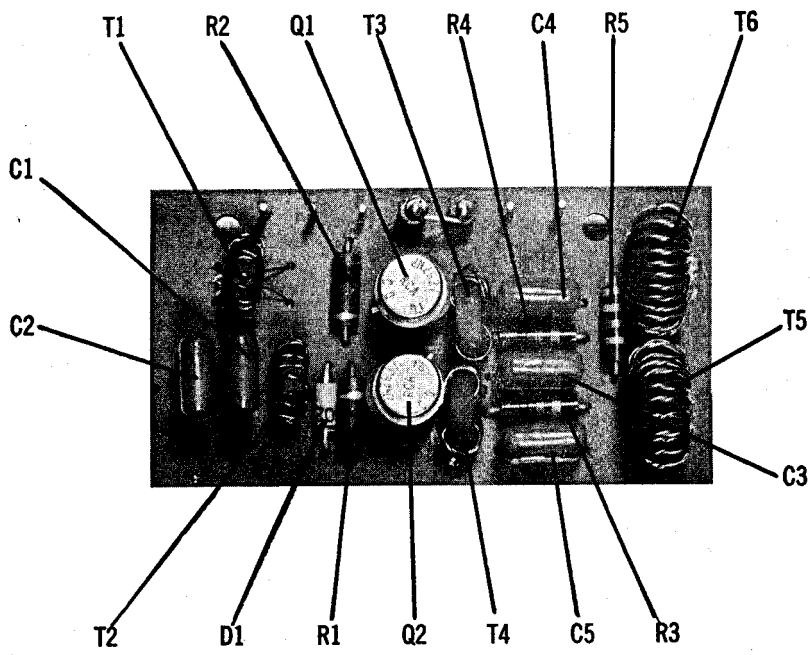

90195 RF POWER AMP

I.F. MODULE

The 9 MHz I.F. is a single stage consisting of transistor Q1 and transformer T1. The input is not tuned. The output of the I.F. stage feeds a low distortion product detector. The recovered audio is amplified by transistors Q3, Q4 and Q5. The output of this pre-amplifier is brought out to a terminal pin and also drives the AGC circuitry. Transistor Q6 provides the low impedance necessary for proper operation of the voltage doubler circuit consisting of the two 1N4154 diodes. The 125 mfd capacitor removes any ripple from the AGC line and provides the proper attack and decay characteristics. Transistor Q7 is used to clamp the AGC line to ground during transmitting. This eliminates any tendency of receiver blocking caused by stray RF in the AGC circuit. The clamping action is achieved by applying a positive voltage to the "T" terminal. The I.F. amplifier bias is brought out to terminal "R". This may be connected to +12 VDC or used for AGC control of the amplifier. The AGC output terminal is not intended for direct connection to pin "R". It is simply a control voltage to be used with an auxiliary AGC system.

SPECIFICATIONS

MAXIMUM AUDIO OUTPUT : 2.6 VRMS SIZE : HWD 2" x 5½" x 2½"

OUTPUT IMPEDANCE : 500

INPUT VOLTAGE for maximum output : 300 uv

AGC VOLTAGE (6.8 K load/maximum signal) : +2.5 V.D.C.

BFO : 1.0 ; 3.0 VRMS

VOLTAGE READINGS

	COLLECTOR	BASE	EMITTER
Q1	+12.0	+1.3	+ .7
Q3	+6.0	+ .7	+ .1
Q4	+3.0	+ .7	+ .1
Q5	+6.0	+3.0	+2.4
Q6	+12.0	+5.6	+5.0
Q7	0	0	0
Q2	Source <u>+1.5</u> Drain <u>+8.0</u> Gate 1 <u>+1.5</u> Gate 2 <u>+ .7</u>		

The above measurements were taken with a VTVM under no signal conditions. Pins viewed from bottom of board



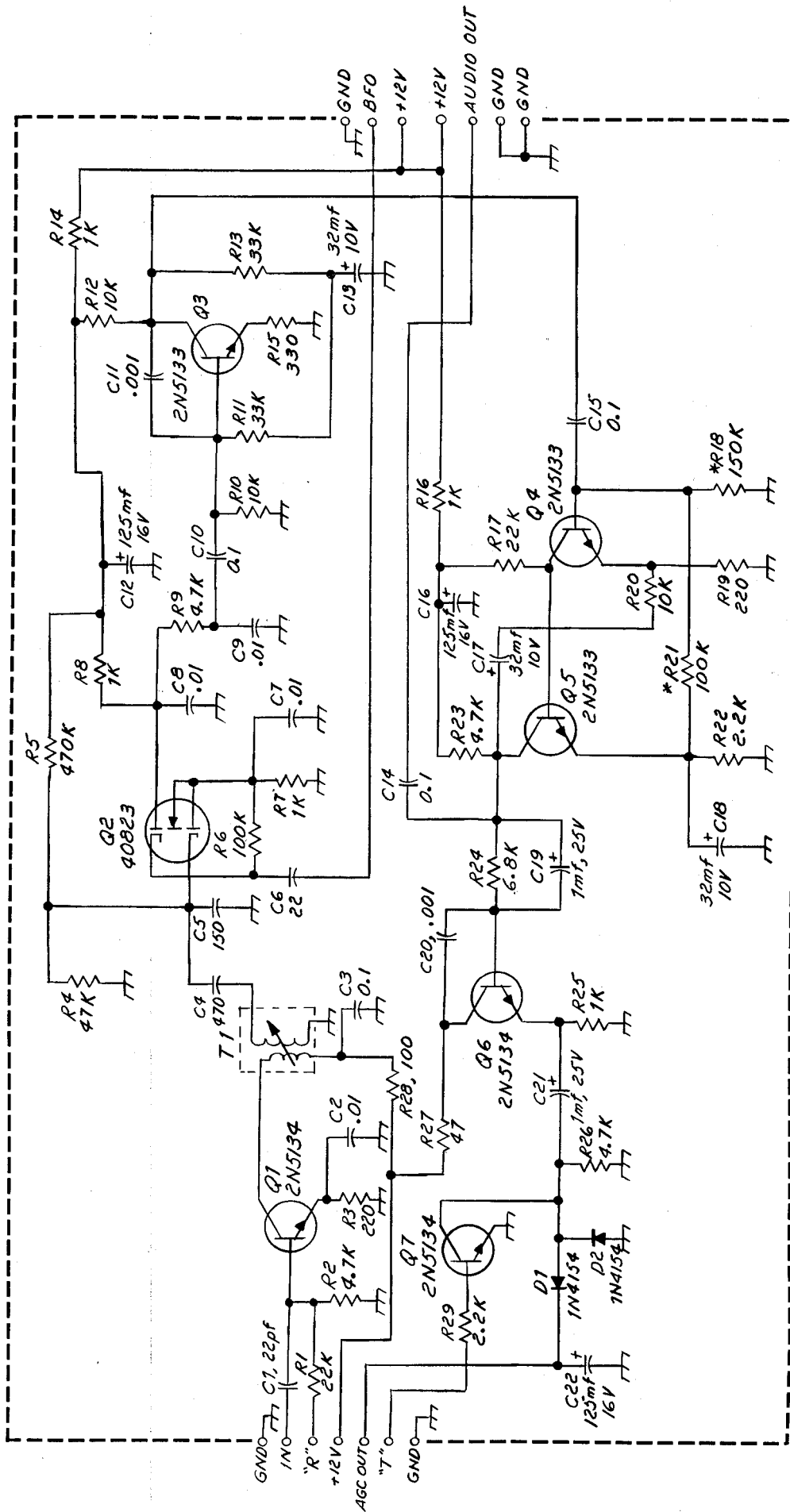

I.F. BOARD

* Adjust for 6 Volts at collector of output 2N5133, Q5.

Pins viewed from top of board.

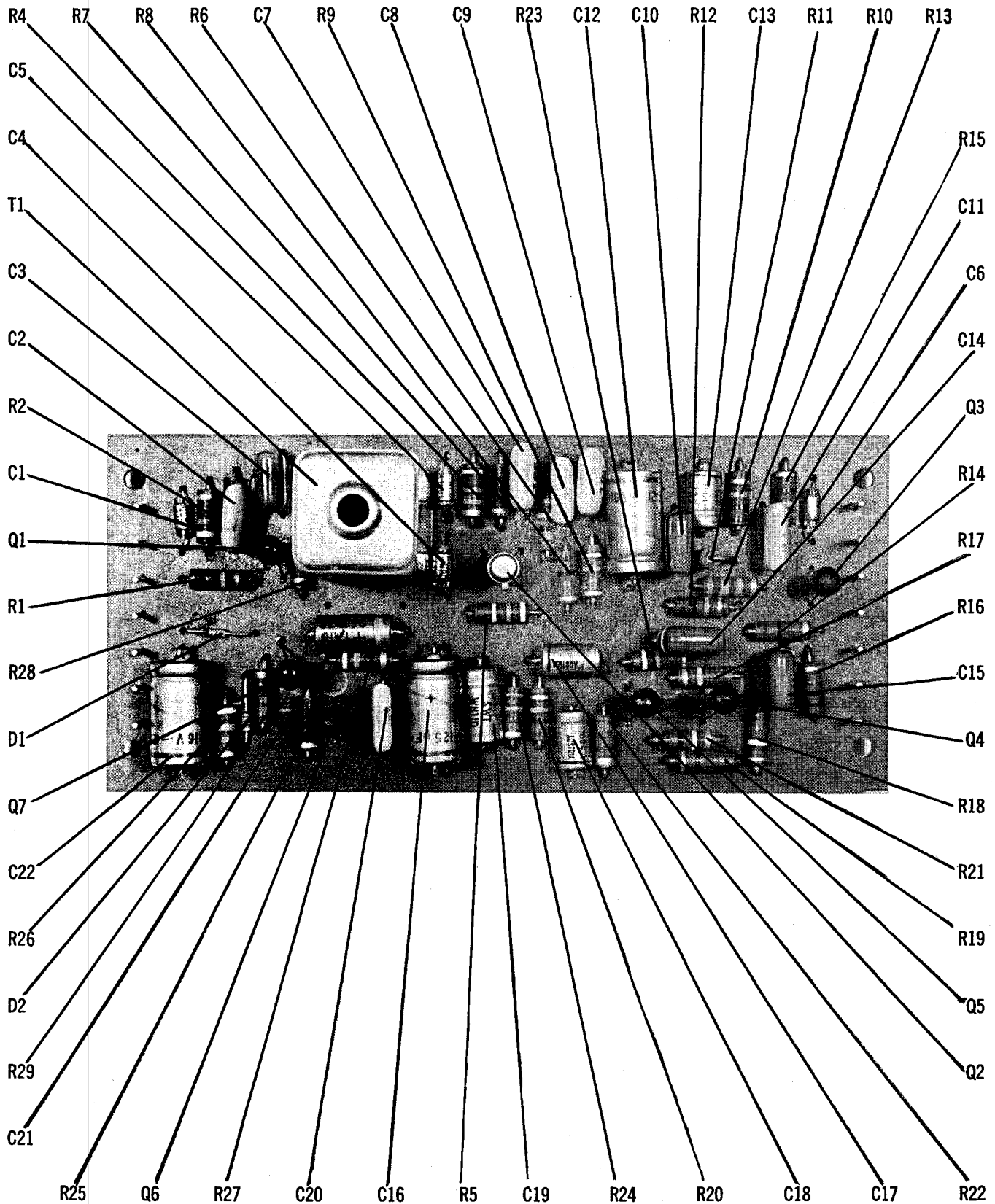

90184 IF BOARD

AUDIO AMPLIFIER

Transistors Q1, Q3, Q4 and Q5 comprise a DC coupled complementary audio amplifier. Sufficient feedback, both AC and DC, is used to insure stability under varying voltage source and provide extremely low distortion. Transistor clamp Q6 reduces the gain over 70 dB with a positive 10 volts applied to terminal "T". Transistor Q2 operates as an audio oscillator to monitor keying. It is activated by applying a positive keyed voltage to the pin labeled "side-tone". A side-tone level control is provided on the circuit board to set the monitor level. Any speaker impedance above 4 ohms works satisfactorily.

SPECIFICATION

POWER OUTPUT : 1w \pm 1dB SIZE : HWD 1 1/2" x 3 3/4" x 2 1/2"

HARMONIC DISTORTION : 2%

INPUT IMPEDANCE : 33K

IDLE CURRENT : 25 mA

MAXIMUM CURRENT : 200mA

SENSITIVITY : 400 mv for 1 watt

POWER SUPPLY VOLTAGE : 12 to 18 VDC

VOLTAGE READINGS

	COLLECTOR	BASE	EMITTER
Q1	+6	+5.2	+5.8
Q2	+12	+4.2	+3.7
Q3	+6.2	+6	0
Q4	+12.0	+6.5	+6.4
Q5	0	+6.2	+6.3
Q6	0	0	0

The above measurements were taken with a VTVM under no signal conditions. Q2 measurements were taken with the side-tone pin connected to a +10 V source. These readings will vary from transistor to transistor and are meant as a guide only.

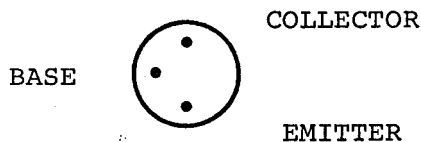

Transistor pin arrangement viewed from the bottom of the transistor.

Pins viewed from top of board.

90186 AUDIO POWER AMP.

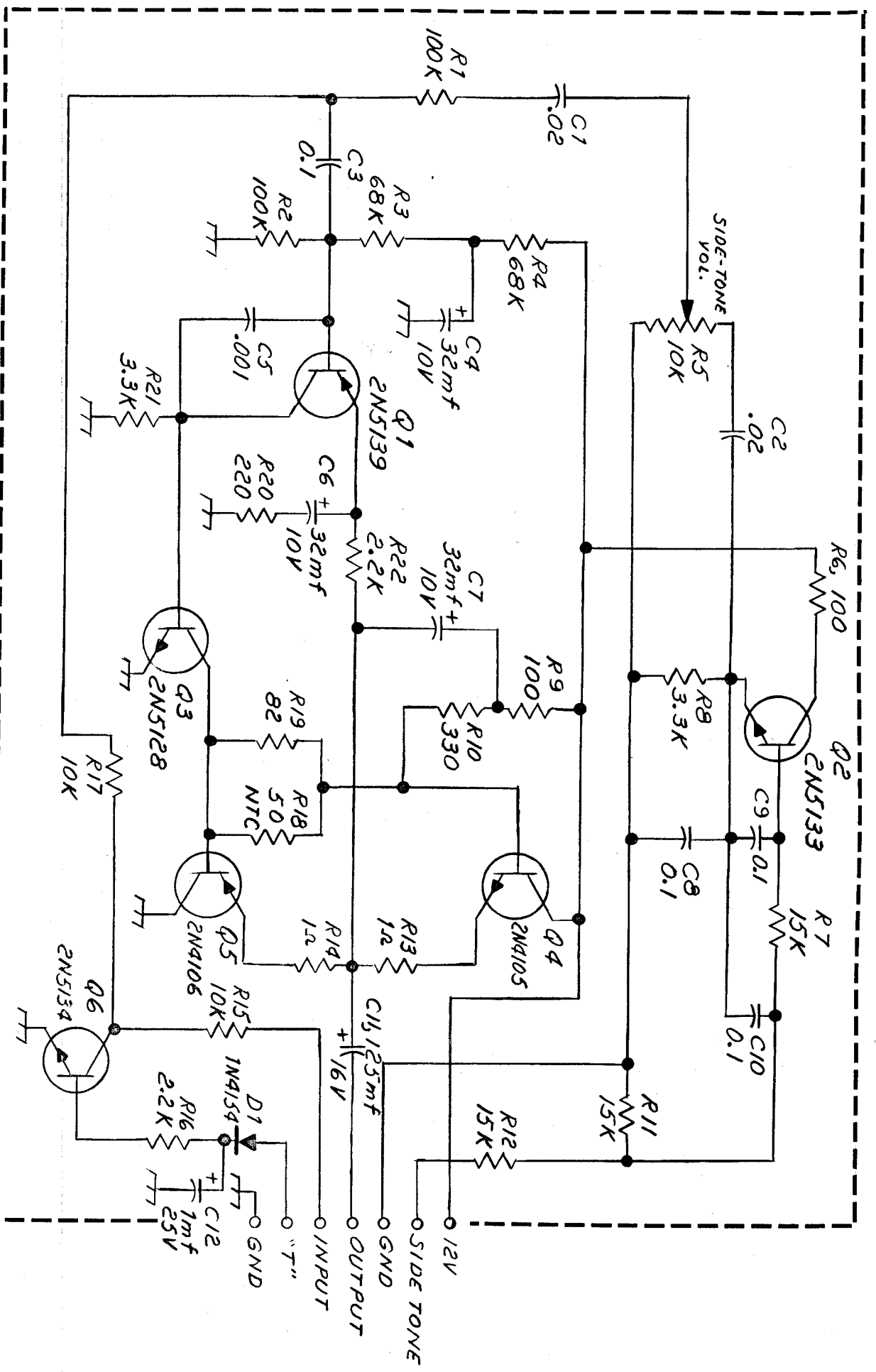

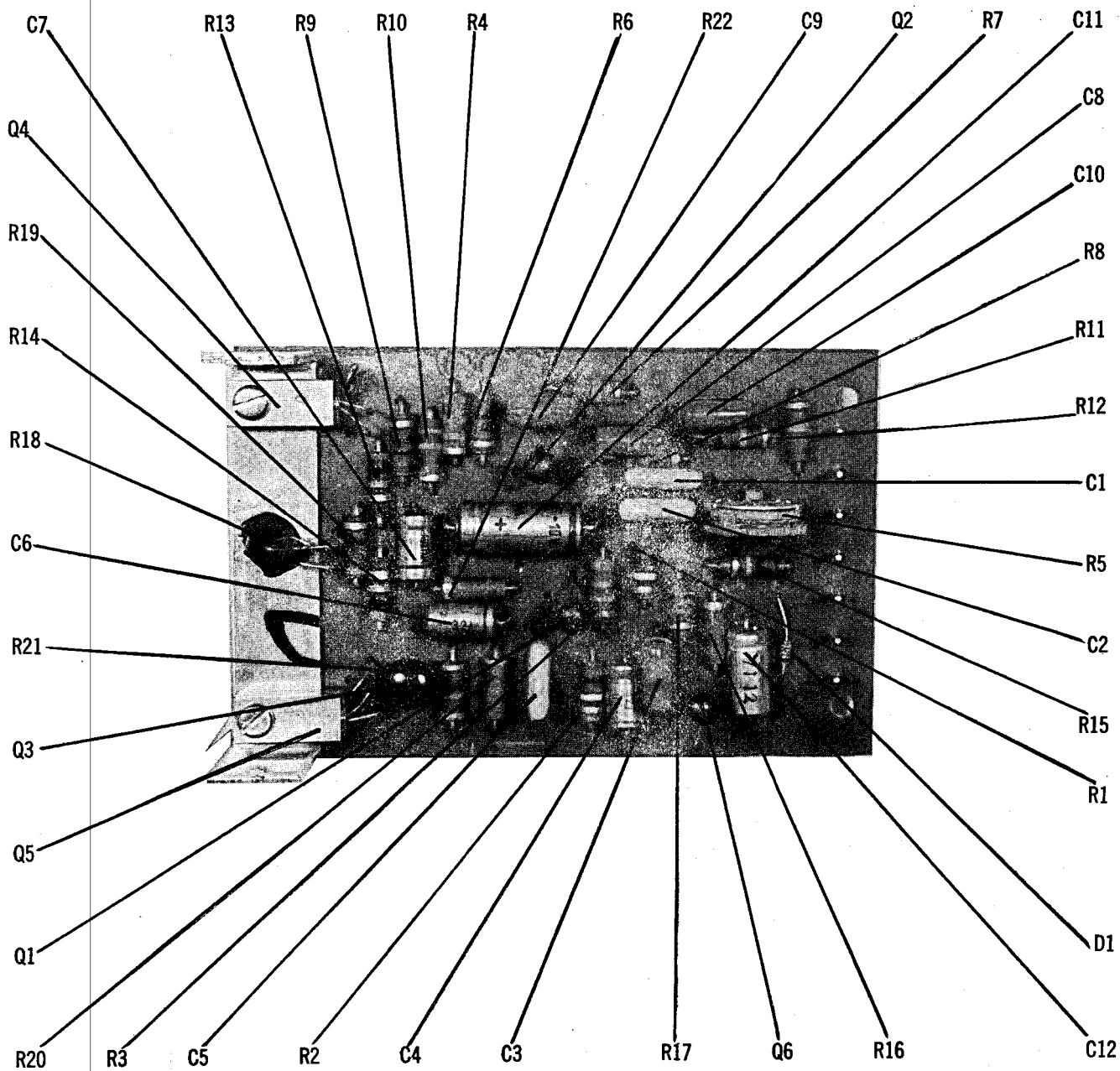

90186 AUDIO POWER AMP

SIDE BAND GENERATOR & FILTER

Transistor Q1 operates as a crystal controlled carrier generator. Capacitors C1, C2 and C3 set the crystal to the proper frequency for USB, LSB and CW. The total output of the oscillator is brought out to a terminal pin for use as a BFO. A portion of this output is fed to the balanced modulator, CA3053. The balanced modulator is an integrated circuit differential amplifier. Using an integrated circuit insures good balance under varying voltages and temperatures. The balanced modulator output passes through a four crystal filter terminated in 470 ohms. Transistors Q4 and Q5 are used as a microphone amplifier.

CONNECTIONS

GND: There are two separate circuit board grounds. Be sure both are connected to chassis.

+12V: Main power to the balanced modulator and microphone amplifier.

+9V: Used for the carrier oscillator and must be regulated for maximum stability.

"T": Controls the balanced modulator bias. Must be connected to +8 to +12 V source for proper operation in transmit. Can be switched off during receive to reduce current drain and eliminate any possibility of interaction between the transmitter and receiver stages in a transceiver.

BFO: To be used with an external product detector in a transceiver.

LSB/CW: Capacitor C1 sets the crystal to the high frequency side of the filter passband. A positive 8 to 12 V at terminals "LSB" and "CW" will cause transistor switches Q2 and Q3 to place capacitors C2 and C3 in the circuit. These capacitors will set the crystal to the low frequency side of the filter passband. Both the upper and lower frequency carriers are positioned approximately 15 dB down on the filter skirts. For CW operation, the "CW" pin is brought to ground with a suitable switch. This removes capacitor C3 and places the generator in the filter passband. Frequency change is approximately 700 Hz.

OUTPUT: The output termination of 470 ohms has been included on the board. It should not be loaded with less than 4700 ohms and 22 pf. If a lower impedance load is to be used, the internal resistor may be changed.

MIC VOL: These two pins and ground are connected to the microphone volume control. (25K linear)

MIC: Input to the microphone amplifier. Will accept high impedance crystal, ceramic, or dynamic microphones.

RX IF: To use the filter in the receiver I.F., connect the output of the receiver mixer to the "output" terminal and the receiver I.F. input to the "RX IF" terminal. The load at this point should be greater than 4700 ohms.

CWD: This terminal should be switched to ground to unbalance the modulator. This allows the full carrier to be passed through to the filter output when operating CW.

ALIGNMENT

Set the capacitor C1 to maximum capacity and ground the LSB, CW and CWB terminals. Tune T1 for maximum output from the filter. Rotate C1 until the output drops approximately 15 dB. This sets the carrier to the high frequency side of the filter. Set both C2 and C3 to maximum capacity. With both LSB and CW connected to a positive voltage (8 to 12 V), the carrier should be approximately 15 dB down from maximum output. Ground the "CW" pin and tune C2 until the carrier just reaches a maximum. This should place the CW signal just inside the filter pass-band. C3 should be readjusted, if necessary, to place the sideband carrier approximately 15 dB down the skirt. C3 is usually at or very near maximum capacity. Remove the ground from the CWB pin and null the carrier with the printed circuit potentiometer.

SPECIFICATIONS

POWER : +9 V regulated @ 2.6 mA.
 +12 V @ 11 mA.
 BFO : 2.3 V.R.M.S.
 SIDEBAND OUTPUT : .5 V.R.M.S. two-tone test
 FILTER : 2.5 kHz @ 6 dB, 4.25 kHz 50 dB
 CARRIER REJECTION : 40 dB
 SIDEBAND REJECTION : 30 dB from 1000 Hz. Reference
 OUTPUT IMP : 470 ohms

MICROPHONE AMPLIFIER -

INPUT IMP 68K
 INPUT SENS 5 mv
 VOLUME CONTROL, 25K linear
 SIZE : HWD 2" x 4 3/4" x 2 2/3"

VOLTAGE READINGS

	COLLECTOR	BASE	EMITTER		CA3053
Q1	+8.5	+6.0	+6.1	1	+8.2
Q2	0	-2.2	0	2	+3
Q3	-.2	-.1	0	3	0
Q4	+3.4	+6.6	+0.8	4	+2.4
Q5	+6	+3.4	+2.8	5	+2.0
				6	+12
				7	+12
				8	+12

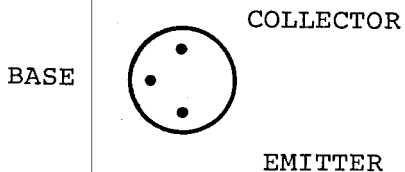

Transistor and I.C. pin arrangement viewed from the bottom of the board.

The above readings were taken with pins LSB, CW grounded. Pin "T" to +12 V. All readings with a VTVM.

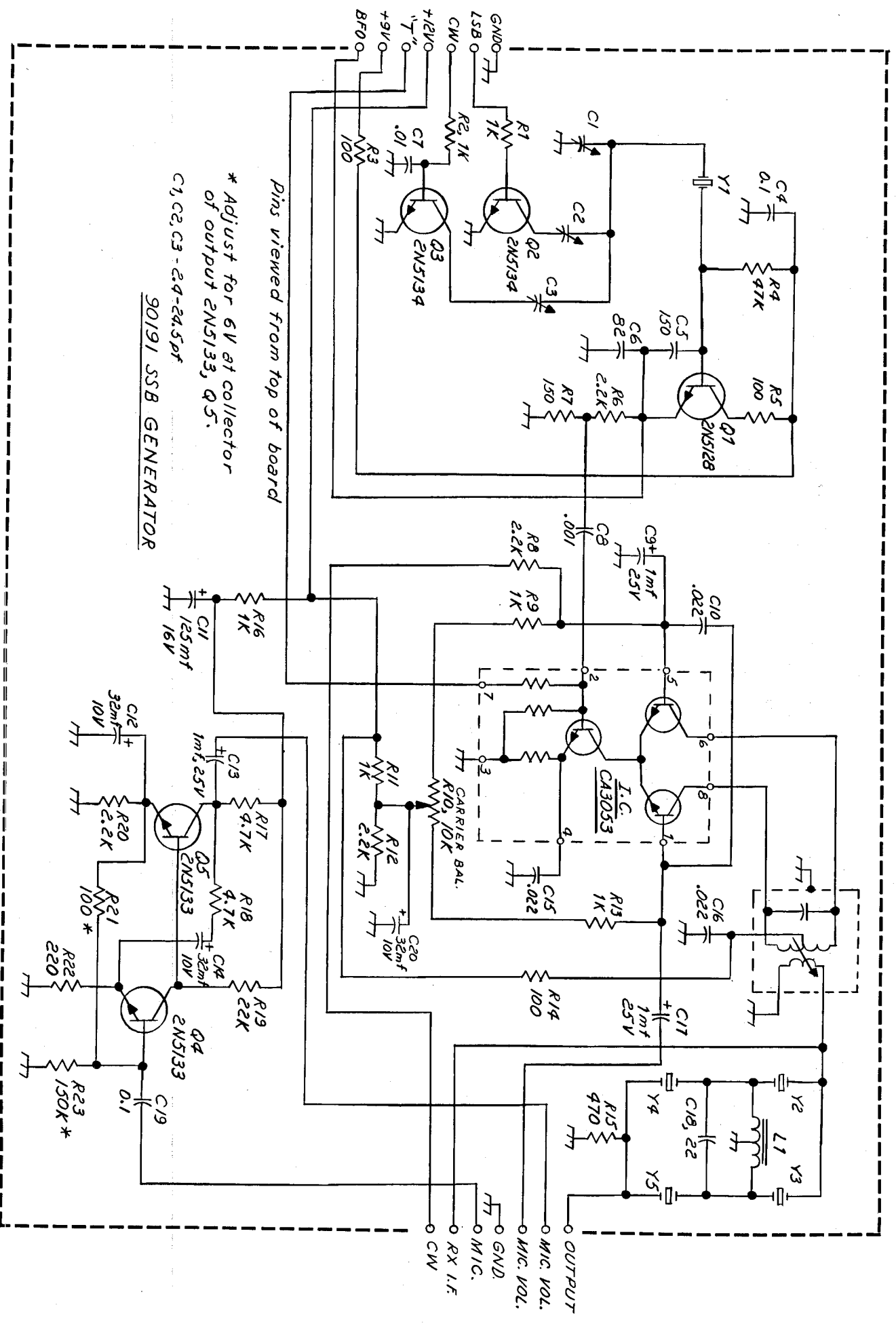

** Adjust for 6V at collector of output 2N5133, Q5.*

90191 SSB GENERATOR

Pins viewed from top of board

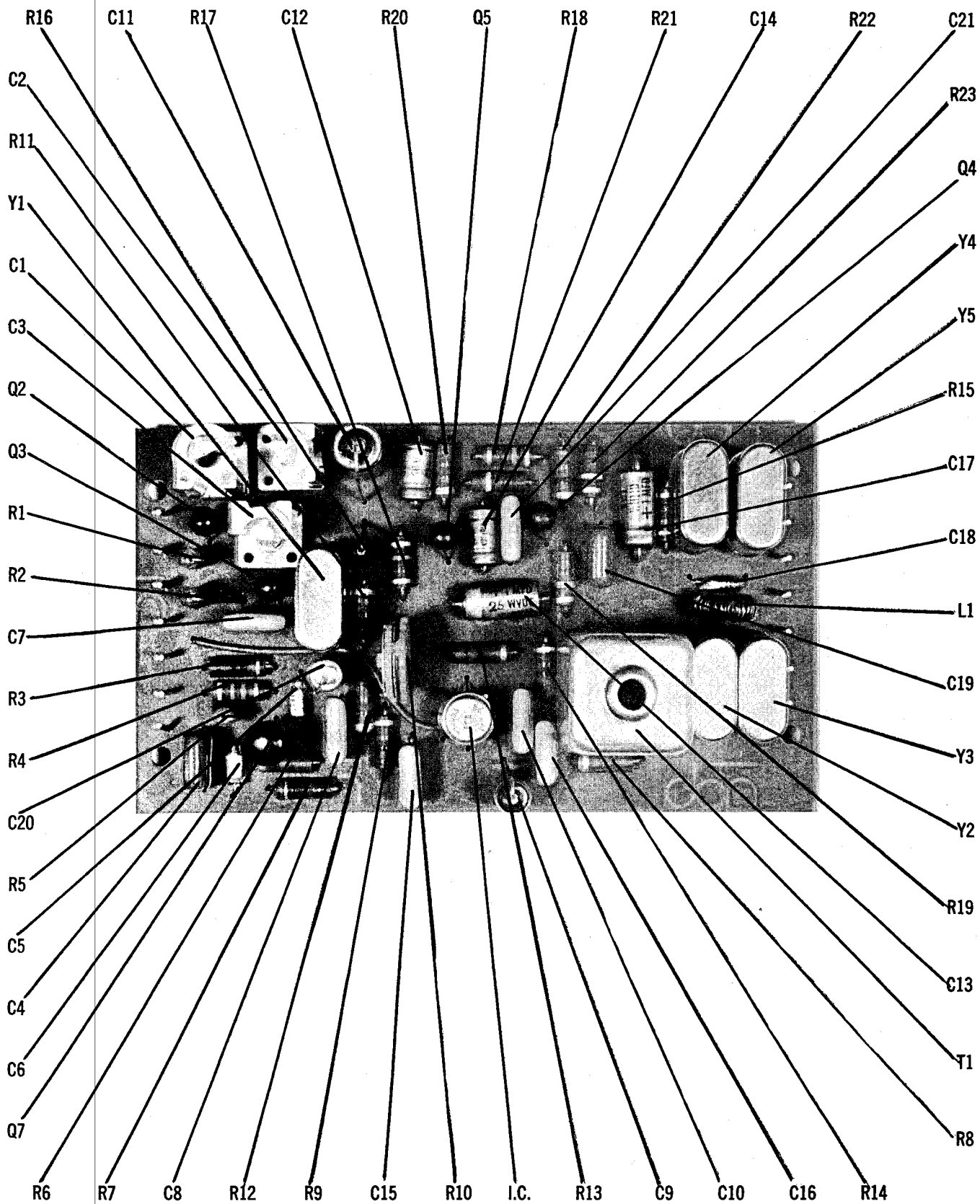

90191 SSB GENERATOR

CONTROL BOARD

Transistors Q1, Q2 and Q3 form a complementary switch. The output, connected to pin "T" is normally at ground potential. Transistors Q4, Q5 and Q6 form a similar switch. Their output, pin "R", is normally at +12 VDC. The "T" pin is intended for biasing the transmitter stages and the "R" pin for biasing the receiver stages. When the T/R pin is grounded, the potentials at "T" and "R" reverse. That is, "T" goes to +12 V and "R" goes to ground. In addition, the relay is thrown and connects the antenna from the receiver to the transmitter. Transistors Q7 and Q8 form a 9 V regulated supply, and are used with oscillator circuits. The receive bias switch (Q4, Q5, Q6) may also be used as an AGC amplifier. A positive AGC voltage applied to the AGC pin controls the voltage at the "R" pin. This is independent of the voltage at the "T" pin. An S-Meter may be added by connecting a 500 micro-ampere meter between the "R" pin and the pin labeled S-Meter. The S-Meter zero, sets with the thumb pot on the circuit board.

A control voltage and switching for offset tuning has been incorporated. A 10 K linear potentiometer is connected to the two pins marked "Offset". The potentiometer wiper connects to the varactor circuit in the oscillator. The control voltage will vary between 3 and 6 V. Transistor Q9 disables the offset tuning during the transmit mode. The pin marked "offset on/off" is connected through a switch to the "T" pin. During transmit, or when the switch is opened, transistor Q9 conducts and shorts the offset potentiometer. This places the offset voltage midway between the extremes available on the potentiometer. There is a small residual left across the potentiometer due to the transistor saturation voltage. This is in the area of .2 to .3 V. Varying the potentiometer from one extreme to the other during transmit or when the switch is open will still vary the frequency slightly. This variation will be in the order of 5% of the frequency swing available when the offset is working. A printed circuit potentiometer on the circuit board adjusts the offset center frequency. With the offset on and the knob centered tune in a signal. Turn the offset off and adjust the potentiometer to produce the same frequency.

SPECIFICATIONS

SUPPLY VOLTAGE : 12-14 V

REGULATED OUTPUT : 9 V @ ma.

MAXIMUM CURRENT AVAILABLE at the "R" or "T" PIN : 40 ma.

AGC VOLTAGE : 0 to +3 VDC

SIZE : HWD 1 1/4" x 4 3/4" x 2 1/4"

VOLTAGE READINGS

	COLLECTOR	BASE	EMITTER
Q1	.15	+.85	0
Q2	0	.15	+.15
Q3	+12	.15	+.15
Q4	+11	.05	0
Q5	0	+11	+10
Q6	+12	+11	+10
Q7	+12	+10.5	+9.5
Q8	+10.5	+.7	0
Q9	+4.8	+5.2	+4.6

The above measurements were taken with a VTVM and the T/R pin open. Voltages on Q9 are with the offset inoperative.

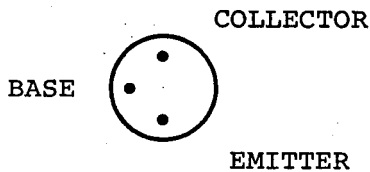

Transistor pin arrangement viewed from the bottom of the transistor.